

H2Optimo EZ-Tap LC System

TECHNICAL DRAWING



FEATURES AND BENEFITS

- Provides clear, clean, fresh ingredient quality water for drinking water, carbonated and non-carbonated beverages.
- Automatic shut off valve
- 1 micron filterability reduces dirt and particles as small as 1 micron.
- H2Optimo filtration reduces chlorine taste, odor and color and other contaminants.
- Improves the taste of fountain beverages and helps retain carbonation.
- Protects drink system pumps, solenoids, and valves.
- Sanitary quick change cartridge. Internal filter is not exposed to handling or contamination.

H2Optimo EZ-Tap LC System

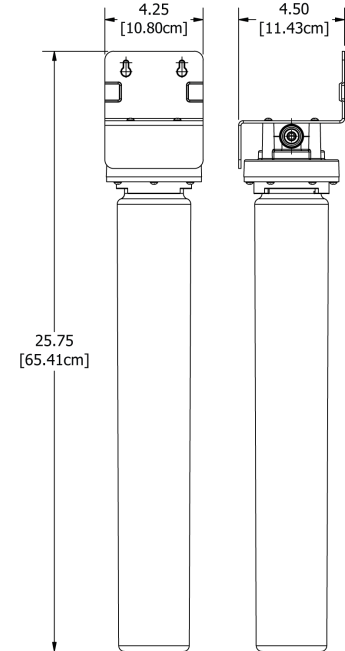

H2Optimo EZ-Tap LC System Part #92170

H2Optimo LC Replacement Cartridge Part #92107

APPLICATIONS

FOUNTAIN BEVERAGE Single Carb Pump	ICE	COFFEE/ ESPRESSO/TEA	DRINKING WATER Glass Filler or Bar Gun	STEAMER	WAREWASHING
--	-----	-------------------------	--	---------	-------------

OPERATIONAL TIPS

- Change cartridge on a scheduled 6-month maintenance program.
- Use a 3/8" O.D. water line connection.
- Install in a vertical position.
- Mount the head to the wall surface using appropriate wall anchors.
- Allow 3" clearance below the cartridge for replacement.
- Flush the cartridge for 3 minutes at full flow.

H2Optimo EZ-Tap LC System - SPECIFICATIONS

Dimensions:
25.75 H x 4.25 W x 4.5 D – INCH
65.4 H x 10.8 W x 11.43 D - CM
Inlet / Outlet Connection:
3/8" O.D. J.G.-John Guest connections

Max Flow Rate – 1.67 GPM (6.34 LPM)
Chemical Capacity – 11,000 GAL (41,800 LTR)
Filtration Rating – 1 micron
Ship WT – 4.72 LBS (2.14 KGS)
Operational WT – 6.64 LBS (3.01 KGS)
Working Pressure – 10-100 PSI (0.7-6.8 BAR)
Water Temperature – 35-100°F (1.6- 37.7°C)

Designed for low flow drinking water and fountain beverage applications where the customer desires cyst protection.

To Order:
Phone: 972.881.9797
Email: CS@optipure.net
Product Info: info@optipure.net
Freight: fob Plano, TX

LC System PN 92170
LC Replacement Cartridge Part #92107
LC Cartridge Case of 6 Part #92052