



## Display Unit Refrigerated Counter Top 900mm

*“Anvil’s Display Units are perfect to enhance your products in a point of sale position. They are designed to keep cakes at the correct temperature for holding and serving.”*

**Model: YFC0900**

### APPLICATION

- These units are ideal for coffee shops, bakeries and canteens
- Anvil Cake Display unit will attractively store your product after the baking process and display your products in a safe environment

### CONSTRUCTION

- Modern design
- Illuminated shelf and base
- 2 Adjustable shelves
- Digital display and temperature control
- Automatic defrost
- Low noise
- Tempered heated glass
- Designed for tropical conditions
- Capacity 115 lt

### HEATING

- Temperature range +2°C to +8°C at ambient temperature of 30°C



**ANVIL**

**AIRE**



**ALL ANVIL EQUIPMENT COMES WITH A ONE  
YEAR WARRANTY ON COMPONENTS AND  
DEFECTIVE WORKMANSHIP.**

[www.anvilworld.com](http://www.anvilworld.com)

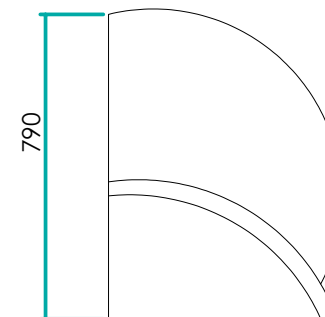
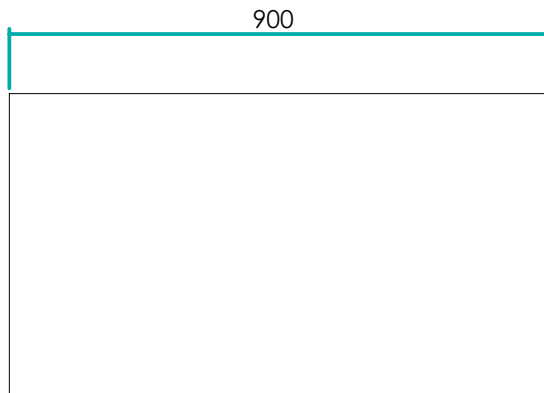

## DESCRIPTION

MODEL  
POWER RATING(230V/50Hz)  
DIMENSIONS (mm) (W x D x H)  
BOX DIMNS (mm) (W x D x H)  
PACKED WEIGHT (kg)

- Unit available in 120V/60Hz configuration

## DISPLAY UNIT REFRIGERATED COUNTER TOP

YFC0900  
0.42kW  
900 x 540 x 790  
950 x 590 x 850  
90

## Model: YFC0900

NOTE: When viewing the appliance from the front in it's usual operating position, the width (W) of the product is the total distance from left to right; the depth (D) of the product is the total distance from the front to the back; the height (H) is the total distance from the bottom of the product to the top.

 ANVIL

# AIRE

Note: Output performance figures quoted are dependant on various factors

Anvil reserves the right, without notice, to make changes and revisions to product specifications, materials and design, which in our opinion, will provide better performance, durability and efficiency.