

Hood type Dishwasher
Undercounter Dishwasher
Glasswasher



GENERAL INSTRUCTIONS FOR INSTALLATION, USE AND MAINTENANCE

eVO **CONCEPT**

W MODELS



MOD:

COP-174 W

COP-504 W

CO-502 W

CO-500 W

CO-402 W

CO-400 W



CODE: 12220401
REV.: 05 (2021)



READ FIRST



**THIS MANUAL MUST BE RETAINED FOR FUTURE REFERENCE.
READ, UNDERSTAND AND FOLLOW THE INSTRUCTIONS AND
WARNINGS CONTAINED IN THIS MANUAL.**



WARNING



**IMPROPER INSTALLATION, ADJUSTMENT, ALTERATION, SERVICE OR MAINTENANCE
CAN CAUSE PROPERTY DAMAGE, INJURY OR DEATH. READ THE INSTALLATION,
OPERATION & MAINTENANCE INSTRUCTIONS THOROUGHLY BEFORE INSTALLING OR
SERVICING THIS EQUIPMENT.**

Model:	Purchased From:
Serial:	Location:
Date Purchased:	Date Installed:
Purchase Order:	For Service, Call:

WARNING	HAZARDOUS VOLTAGE	PLEASE READ INSTRUCTIONS	PROTECTIVE EARTH	EQUIPOTENTIAL BONDING

LIMITED WARRANTY

One Year Parts & Labor Warranty: Fagor Commercial, Inc. ("Fagor") warrants to the first-end-user purchaser (the "User") that the Fagor brand equipment sold hereunder, except for parts and accessories which carry the warranty of a supplier (the "Equipment") will be free from defects in material and factory workmanship under normal conditions of use and maintenance for a period of (1) one year from the date of Installation (Warranty Commencement Date), but in no event to exceed (15) fifteen months from the date of shipment.

Warranty Coverage: If there is a defect in material or factory workmanship covered by this Warranty reported to Fagor during the period the applicable Warranty is in force and effect, Fagor will repair or replace, at Fagor's option, that part of the Equipment that has become defective. Fagor will cover labor cost within one year from the Warranty Commencement date or 15 months from shipment date, whichever occurs first. Fagor shall bear all labor costs in connection with the installation of these replacement parts, provided that, the installation is conducted by Fagor or its authorized representative. Charges for warranty travel time to round trip total (2) two hours or up to 100 miles. Any charges exceeding those stated herein must have prior authorization by Fagor. In case Fagor deems the equipment non-repairable, said equipment will be replaced and the replacement unit(s) will carry the same warranty period from the original unit's installation date (Original Warranty Commencement Date).

Exclusions from and Conditions to Warranty Coverage: This Warranty does not cover parts or accessories, which (a) carry the warranty of a supplier or (b) are abused. Application of this Warranty is further conditioned upon the following:

- **Installation.** The Equipment must be properly installed in accordance with Fagor's installation procedures and instructions and reviewed and tested by a professional technician.
- **No Alteration.** The Equipment must not have been modified or altered from its condition at the date of original installation.
- **Use.** FAGOR EQUIPMENT IS NOT DESIGNED FOR PERSONAL, FAMILY OR HOUSEHOLD PURPOSES, AND ITS SALE FOR SUCH PURPOSES IS NOT INTENDED. IN THE EVENT THE EQUIPMENT IS SO USED, THIS WARRANTY SHALL BE NULL AND VOID, AND THE EQUIPMENT SHALL BE DEEMED TO HAVE BEEN SOLD "AS IS-WHERE IS" WITHOUT ANY WARRANTY OF ANY KIND, INCLUDING WITHOUT LIMITATION ANY WARRANTY OF TITLE, NON-INFRINGEMENT, MERCHANT-ABILITY OR FITNESS FOR A PARTICULAR PURPOSE.
- **Water Quality.** Water supply should have hardness between .25 and 3.0 grains per gallon, pH level between 6.5 – 7.5 and TDS level less than 60 PPM. Equipment failure due to inadequate water supply is not covered by this Warranty.
- **Proper Maintenance and Operation.** The Equipment must be properly maintained and operated in accordance with Fagor's maintenance and operating procedures. All service, labor and parts must be acquired from Fagor or its authorized service representative for the User's area.
- **Minor Parts.** No labor will be associated with the replacement of minor items such as, and not limited to, switches, pilot lights, gauges, fuses, etc. or replacement of wear items such as curtains, squeeze tubes, etc.
- This warranty is void if failure is a direct result of handling &/or transportation, fire, water, accident, misuse, acts of God, attempted repair by unauthorized persons, improper installation, if serial number has been removed or altered, or if unit is used for purpose other than it was originally intended.

Failure to comply with any of these conditions will void this Warranty. In addition, this Warranty does not cover defects due to apparent abuse, misuse or accident.

Fagor will have no responsibility to honor claims received after the date the applicable Warranty expires. Notwithstanding the foregoing, any claim with reference to the Equipment or any parts therefore for any cause shall be deemed waived unless submitted by the User to Fagor within thirty (30) days after the date the User discovered, or should have discovered, the claim. In connection with all claims under this Warranty, Fagor will have the right, at its own expense, to have its representatives inspect the Equipment at the User's premises and to request all of User's records pertaining to the Equipment to determine whether a defect exists, whether the conditions set forth in this Warranty have been satisfied, and whether or not the applicable Warranty is in effect.

THE FOREGOING WARRANTY IS IN LIEU OF AND EXCLUDES ALL OTHER WARRANTIES NOT EXPRESSLY SET FORTH HEREIN, WHETHER EXPRESS OR IMPLIED BY OPERATION OF LAW OR OTHERWISE, INCLUDING BUT NOT LIMITED TO ANY REPRESENTATION OF PERFORMANCE AND ANY IMPLIED WARRANTIES OF TITLE, NON-INFRINGEMENT, MERCHANTABILITY OR FITNESS FOR A PARTICULAR PURPOSE. NO OTHER WARRANTIES ARE AUTHORIZED ON BEHALF OF FAGOR UNLESS SPECIFICALLY ISSUED BY FAGOR.

Fagor shall have no liability for incidental or consequential losses, damages or expenses, loss of sales, profits or goodwill, or punitive or exemplary damages directly or indirectly arising from the sale, handling or use of the Equipment or from any other cause relating thereto, whether arising in contract, tort, warranty, strict liability or otherwise. Fagor's liability hereunder in any case is expressly limited, at Fagor's election, to repair or replacement of Equipment or parts therefore or to the repayment of, or crediting the user with, an amount equal to the purchase price of such goods.

1. INDEX

1. INDEX.....	4
2. GENERAL MEASUREMENTS AND CONNECTIONS	5
3. QUICK STARTUP GUIDES	8
4. ELECTRICAL DIAGRAM	10
5. ELECTRIC DIAGRAMS LEGEND.....	12
6. GENERAL INFORMATION AND WARNINGS	13
7. PRODUCT DETAILS	13
7.1 TECHNICAL SPECIFICATIONS.....	14
8. INSTALLATION INSTRUCTIONS.....	17
8.1 Removal of packaging.....	17
8.2 Positioning and levelling.....	17
8.3 Electrical connection	17
8.4 Hydraulic connection.....	18
8.5 Drainage connection.....	19
8.6 Hydraulic rinse aid dispenser (CO MODELS).....	20
8.7 Electric rinse aid dispenser (COP MODELS).....	21
8.8 Detergent dispenser	22
8.9 Recycling.....	23
9. USE AND MAINTENANCE INSTRUCTIONS.....	24
9.1 Operation.....	24
9.1.1 Control panel symbols.....	24
9.1.2 Switching on the machine	25
9.1.3 Hygiene practices	25
9.1.4 Preparation of the dishes	25
9.1.5 Selecting the wash cycle.....	26
9.1.6 Stopping the wash cycle and end of wash cycle.....	27
9.1.7 Drainage of the machine	27
9.1.8 Switching off the machine	28
9.1.9 Cleaning the machine at the end of the day	28
9.2 Cleaning and Maintenance Instructions.....	28
9.2.1 Routine maintenance	28
9.2.2 Rinse aid and detergent.....	29
9.2.3 Prolonged non use.....	29
10. FAULTS, ALARMS AND BREAKDOWNS	29
10.1 Error diagnosis.....	31

2. GENERAL MEASUREMENTS AND CONNECTIONS

Hood type Dishwasher

COP-174 W

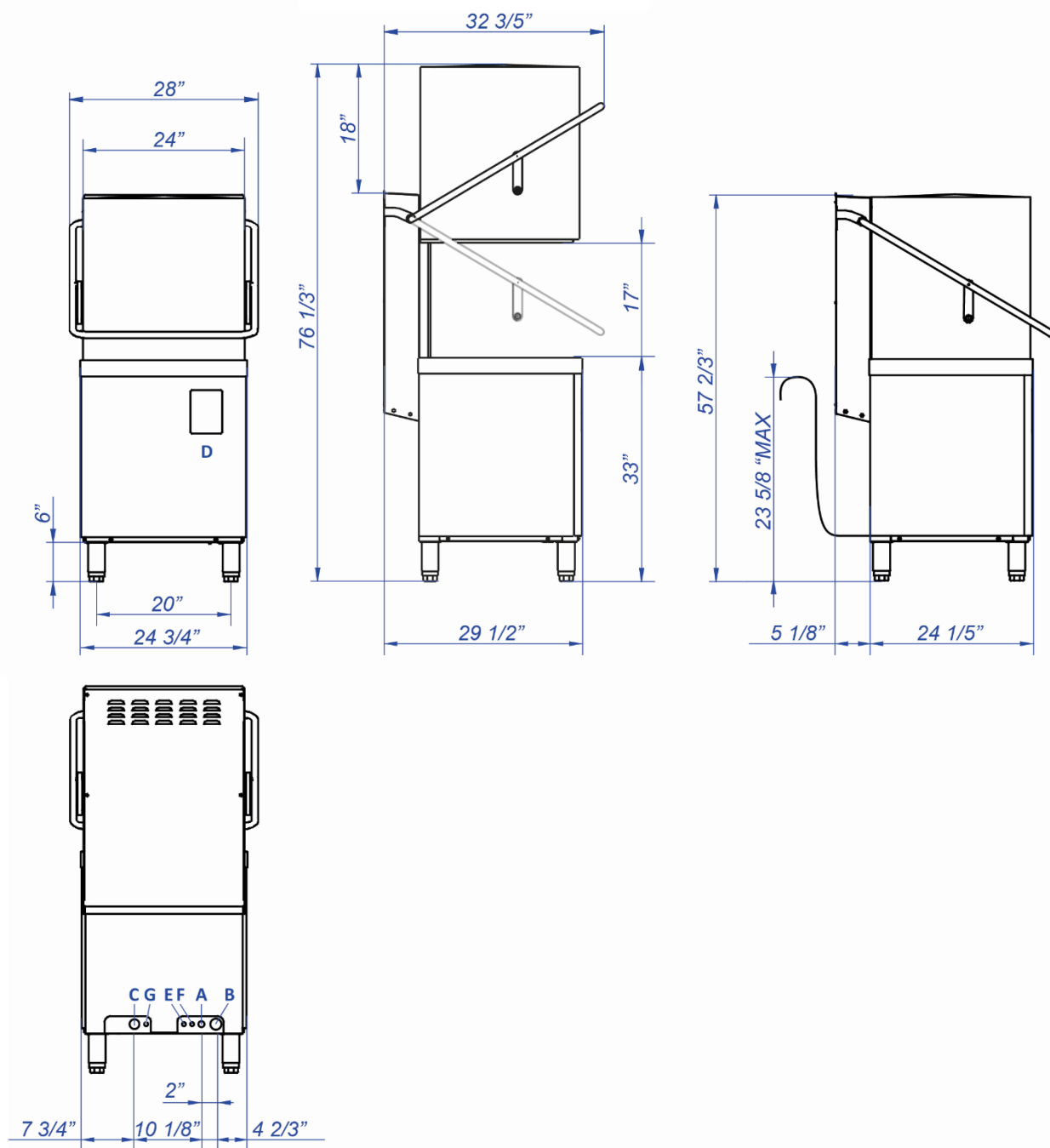

A	B	C	D	E	F	G
Water inlet	Drain hose	Power Supply Cable Strain Relief	Connection Strip (Inside)	Rinse aid inlet	Detergent inlet	Equipotential bond

Hood type Dishwasher

COP-174 W HRS

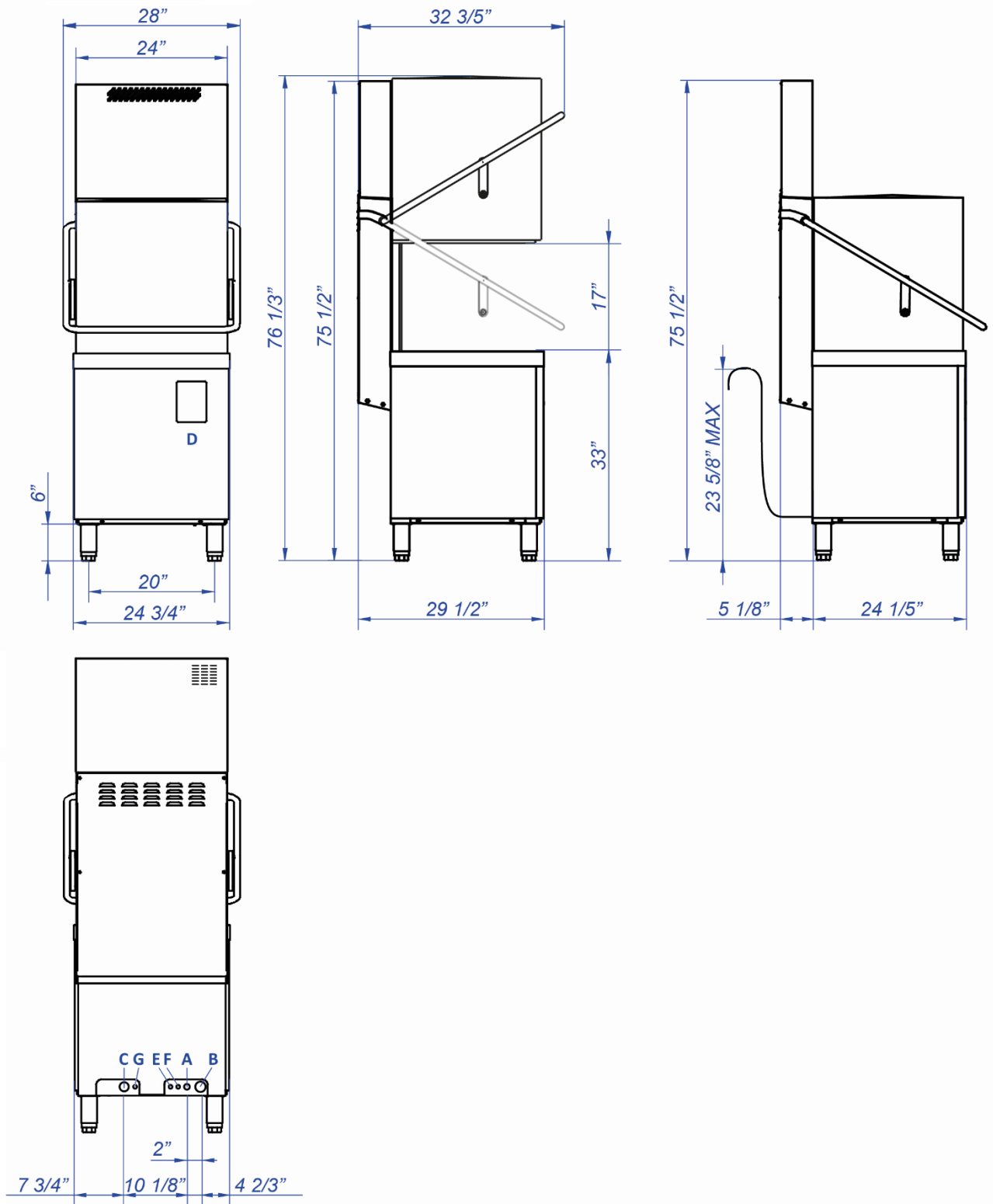

A	B	C	D	E	F	G
Water inlet	Drain hose	Power Supply Cable Strain Relief	Connection Strip (Inside)	Rinse aid inlet	Detergent inlet	Equipotential bond

Undercounter Dishwasher

CO-500 W / CO-502 W / COP-504 W

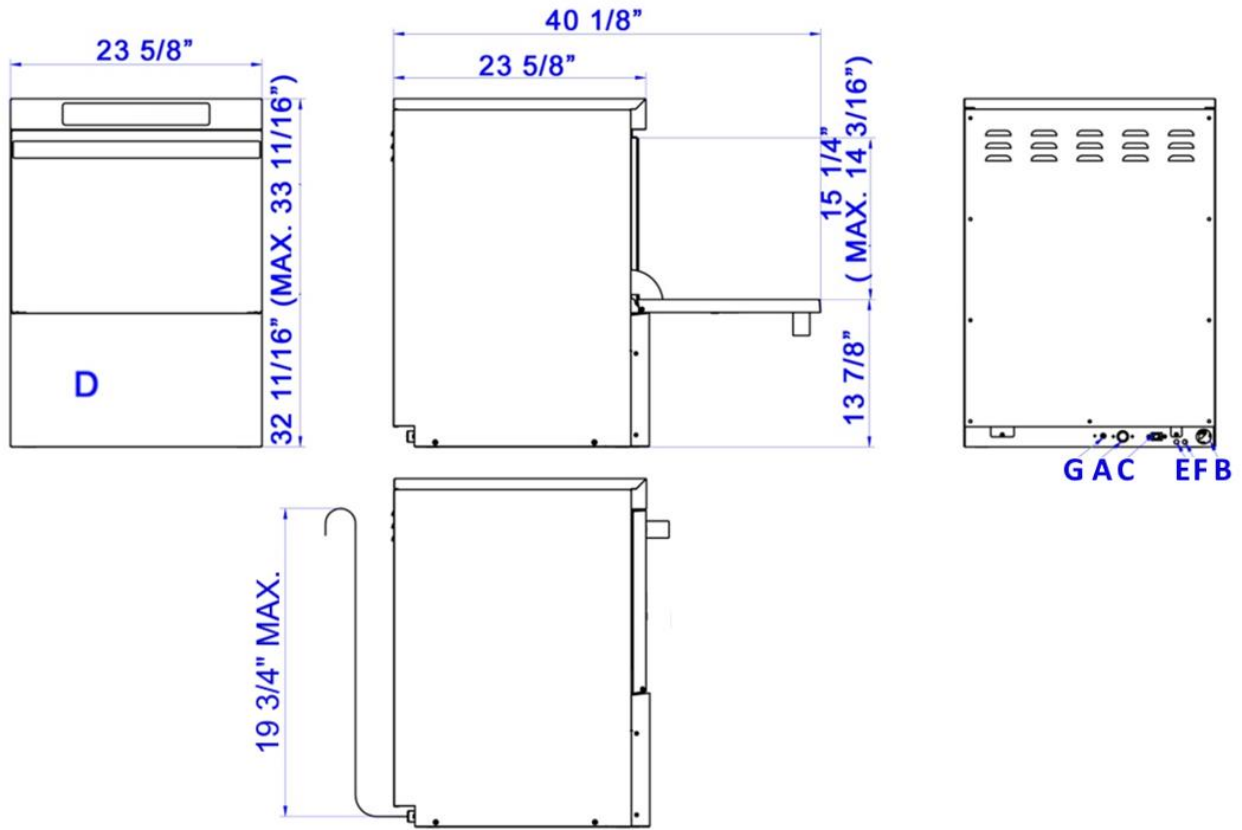

Glasswasher

CO-400 W / CO-402 W

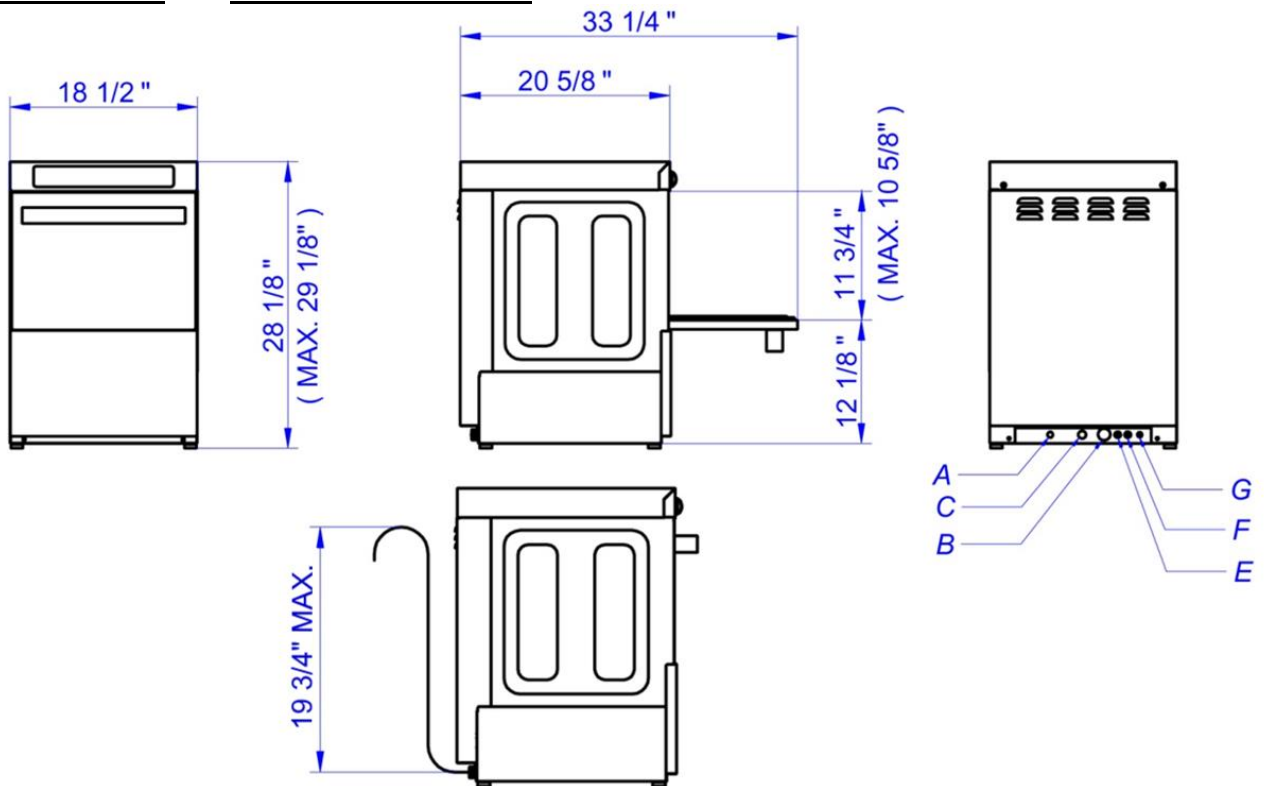





A	B	C	D	E	F	G
Water inlet	Drain hose	Power Supply Cable Strain Relief	Connection Strip (Inside)	Rinse aid inlet	Detergent inlet	Equipotential bond

3. QUICK STARTUP GUIDES

QUICK START GUIDE - EVO Hood-type dishwashers

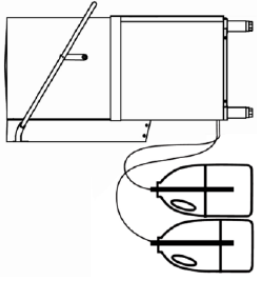
FAGOR 

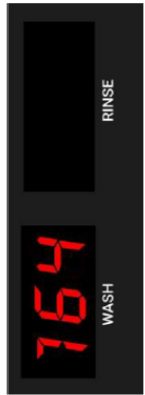
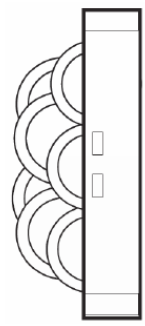
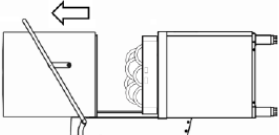

WASH

- 1**  Check chemical levels
- 2**  Turn on: Hold the on/off button for 3 seconds
- 3**  Wait for wash temperature to read between 160-164 °F / 71-73 °C
- 4**  Pre-scrap wares thoroughly
Place in rack
- 5**  Lift hood and load rack into dishwasher
- 6**  Close hood, press P1, P2 or P3 for 1 second or press and hold P3 for 3 seconds to start wash cycle
- 7**

WASH CYCLE IS EXTENDED IF THE FINAL RINSE WATER IS NOT UP TO 180 °F / 82 °C

Cycle is complete when cycle light stops blinking

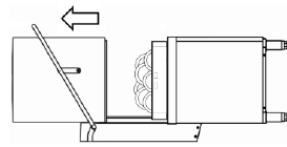
DRAIN

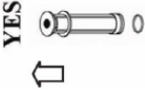
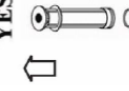
- 1**  Lift hood, remove rack
- 2 Gravity**  Hold on/off button for 3 seconds to turn machine off
- 2 Drain Pump**  Remove overflow tube
- 3**  Remove overflow tube
- 4**



KEEP HOOD OPEN UNTIL WATER HAS DRAINED. CLEAN INSIDE THE UNIT AND REPLACE COMPONENTS
- 3**  With hood open, hold on/off button for 3 seconds to start drain cycle
- 4**

KEEP HOOD OPEN UNTIL WATER HAS DRAINED. CLEAN INSIDE THE UNIT AND REPLACE COMPONENTS

QUICK START GUIDE - EVO Undercounter dishwashers



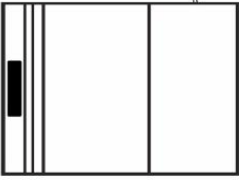

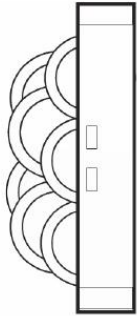
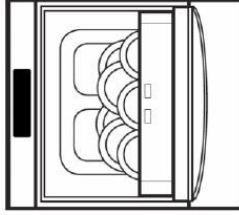
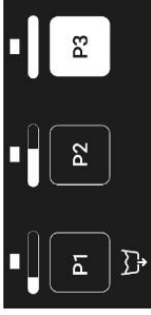

WASH

- 1**  Check chemical levels
- 2**  Turn on: Hold the on/off button for 3 seconds
- 3**  Wait for wash temperature to read between 158-162 °F / 70-72 °C
- 4**  Pre-scrap wares thoroughly
Place in rack
- 5**  Load rack into dishwasher
- 6**  Close door, press P1, P2 or P3 for 1 second or press and hold P3 for 3 seconds to start wash cycle
- 7**

WASH CYCLE IS EXTENDED IF THE FINAL RINSE WATER IS NOT UP TO 180 °F / 82 °C

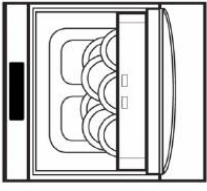
Cycle is complete when cycle light stops blinking

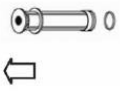
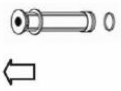
DRAIN

- 1**  Open the door
- 2** **Gravity**
 Hold on/off button for 3 seconds to turn machine off
- 2** **Drain Pump**
 Remove overflow tube
- 3**  YES
 NO!
Remove overflow tube
- 4**

KEEP DOOR OPEN UNTIL WATER HAS DRAINED. CLEAN INSIDE THE UNIT AND REPLACE COMPONENTS
- 3**  With door open, hold on/off button for 3 seconds to start drain cycle
- 4**

KEEP DOOR OPEN UNTIL WATER HAS DRAINED. CLEAN INSIDE THE UNIT AND REPLACE COMPONENTS

4. ELECTRICAL DIAGRAM

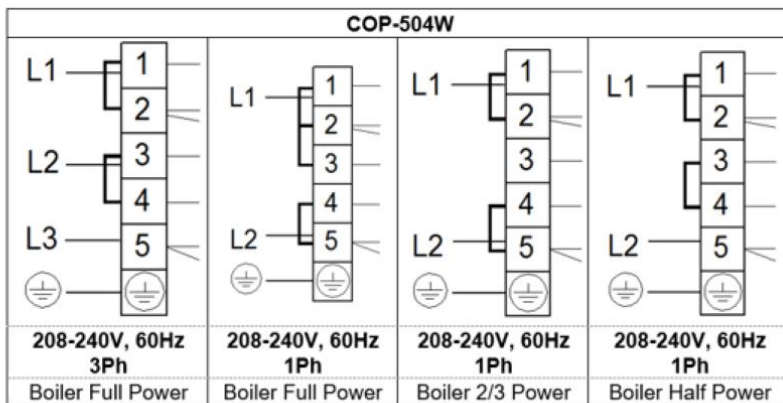
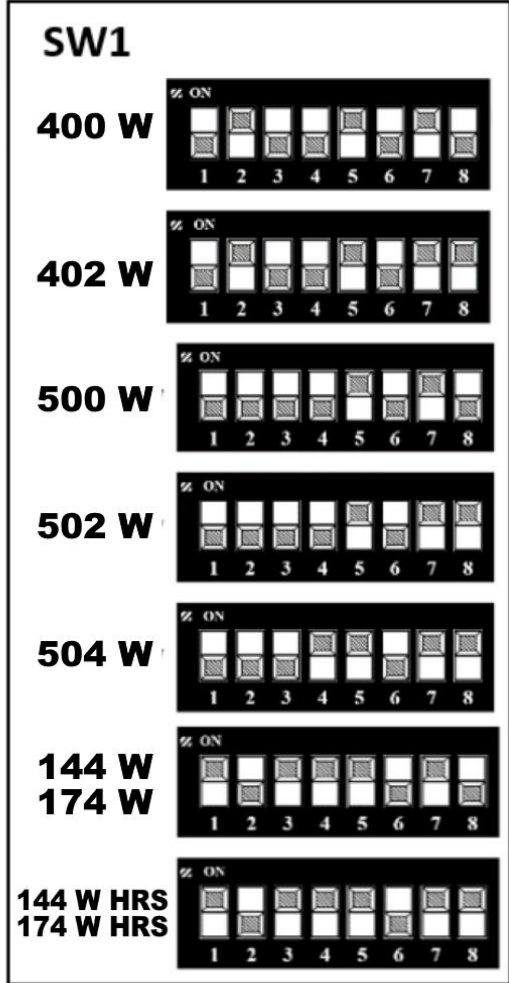
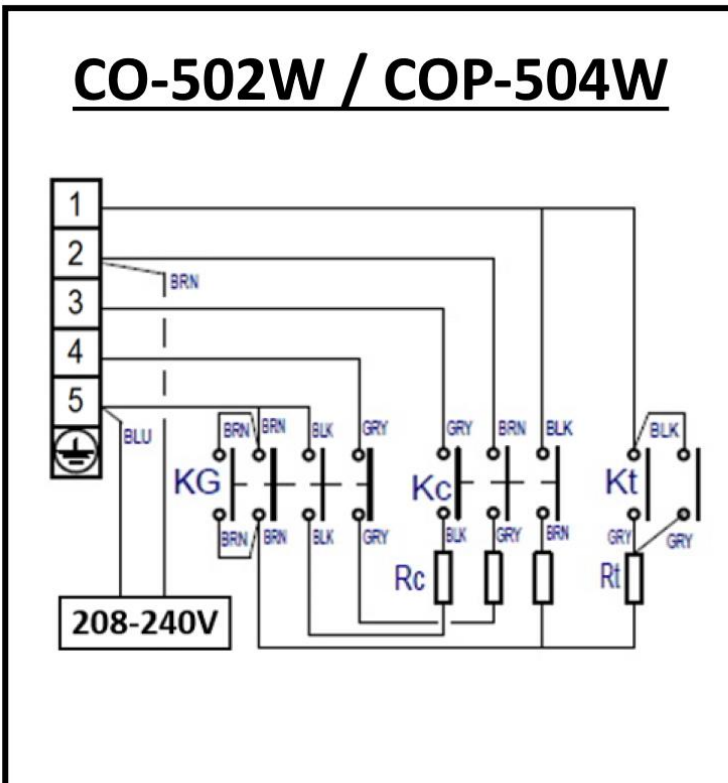
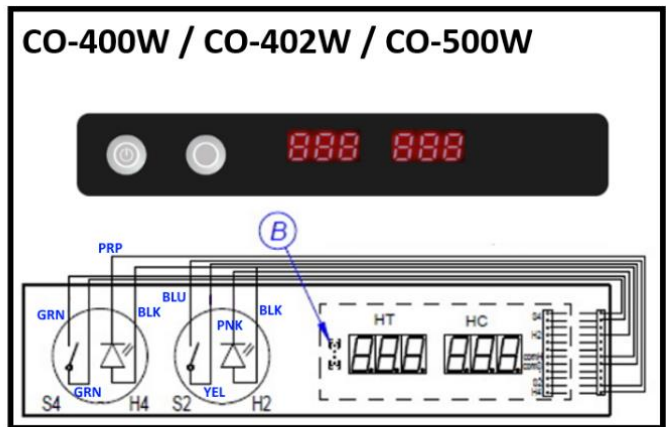
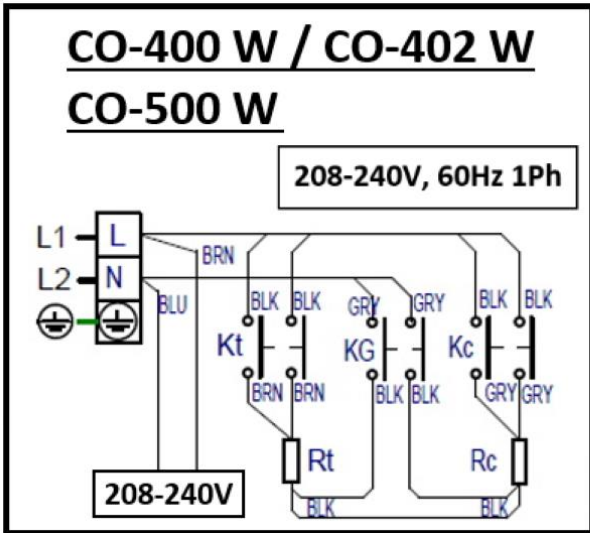

COP-144W COP-174W

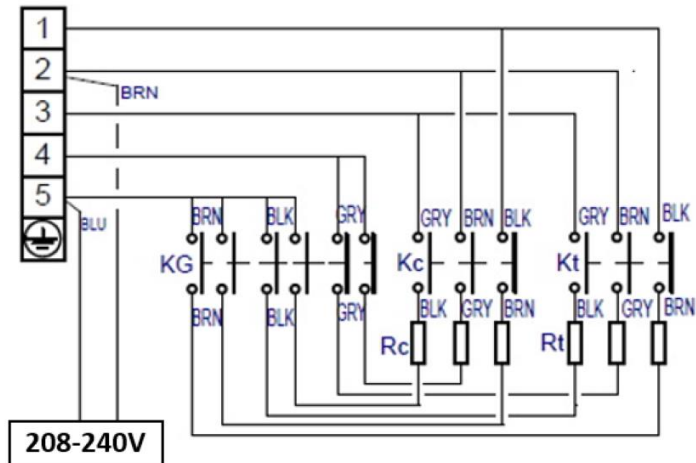
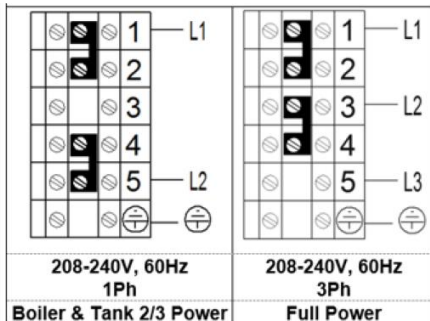

CO-502W / COP-504W / COP-144W / COP-174W

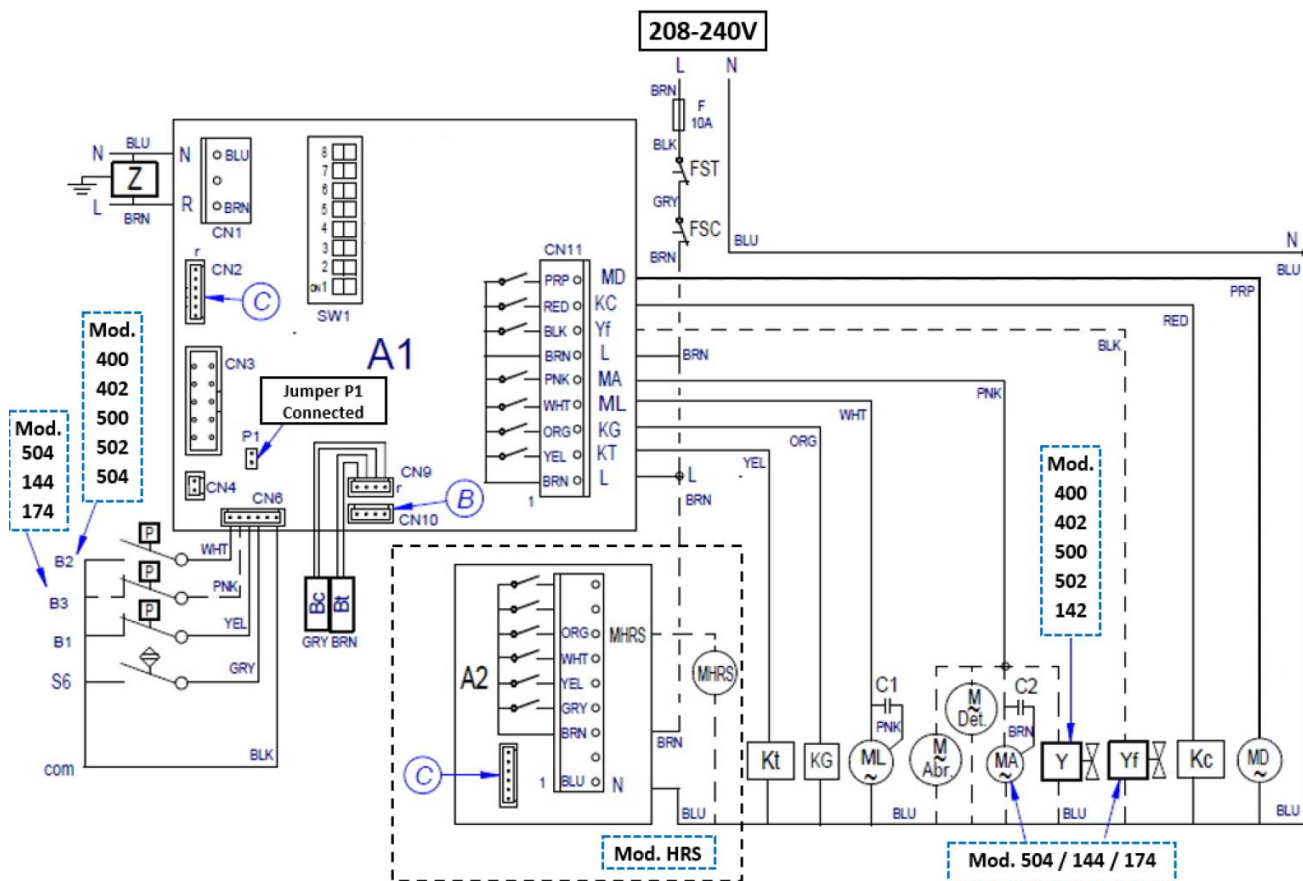
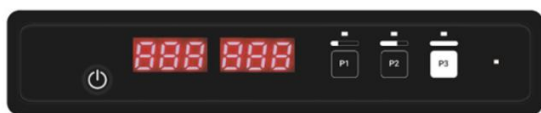

5. ELECTRIC DIAGRAMS LEGEND

	Terminal block bridge	MD	Drain Pump
A1, A2	Electronic Board	MDet	Detergent Dispenser
A1-P1	Electric Bridge / Jumper	MHRS	HRS Fan
Bc	Boiler temperature probe	ML, ML1, ML2	Wash Pump
Bt	Tank Temperature Probe	N	Neutral
C1, C2	Capacitor	P1	Tank Pressure Switch
F	Fuse	P2	Tank Safety Pressure Switch
FSC	Boiler Safety Thermostat	P3	Boiler Pressure Switch
FST	Tank Safety Thermostat	PE / 	Earth Ground
H1, H2, H3	Cycle Light	RC	Boiler Heating Element
H4	Power On Light	RT	Tank Heating Element
H5	Effi-rinse Light	S1, S2, S3	Program/Cycle Push button
HC	Boiler temperature Display	S4	ON/OFF Push button
HT	Tank Temperature Display	S5	Lack of salt switch
KC	Boiler Heating Contactor	S6	Door Switch
KG	Main Relay	SW1	DIP-SWITCH
KT	Tank Heating Contactor	TRF	Transformer
L, L1, L2, L3	Power Supply Phases	Y	Tank Filling Solenoid valve
MAbr	Rinse Aid Dispenser	Yf	Boiler Filling Solenoid valve
MA	Rinse Pump	Z	EMC Filter

	COLOUR
BLK, bk, n	Black
BLU, bl, a	Blue
BRN, bn, m	Brown
GRN, gn, ve	Green
GRY, gy, g	Grey
ORG, or, na	Orange

	COLOUR
PNK, pk, rs	Pink
PRP, pr, vi	Purple
RED, rd, r	Red
WHT, wh, b	White
YEL, yw, am	Yellow
YW/GN, am/ve	Yellow / green

6. GENERAL INFORMATION AND WARNINGS

This manual has been created to help you understand the operation, installation and maintenance of the machine. It contains all the necessary information and warnings to ensure that the appliance is installed and used correctly, together with information about the characteristics and possibilities offered, so that you may enjoy your machine to the full.



BEFORE STARTING THE APPLIANCE, PLEASE READ THE INSTRUCTIONS CONTAINED IN THIS MANUAL CAREFULLY.

The manual should be kept safely to hand for future reference.
If the machine is sold or transferred, please pass the manual to the new user.



THIS APPLIANCE IS EXCLUSIVELY FOR PROFESSIONAL USE AND SHOULD ONLY BE USED BY QUALIFIED PERSONNEL.

- The positioning and installation, and all repairs or modifications, should always be carried out by an **AUTHORISED TECHNICIAN**, in accordance with the applicable legislation of the country. The manufacturer does not accept liability if the machine is incorrectly installed.
- The installation, incorrect adjustment, inappropriate maintenance or use of the appliance may cause material damages and injuries.
- The dishwasher should be correctly levelled, and care taken to ensure that none of the electric cables, water or drainage hoses are trapped or kinked.
- **DO NOT** climb on top of the dishwasher or place heavy objects on top of the machine as it has only been designed to bear the weight of the basket of plates to be washed.
- **The dishwasher is designed for washing plates, glasses and other kitchenware with traces of human food. Any other objects must not be washed in the machine.**
 - If your machine breaks down, please call the **Technical Service Centre**.
 - Unqualified or unauthorised personnel must **NOT** try to repair the machine.
 - Use of spare parts other than original parts will cancel the guarantee.
 - During all maintenance operations, the dishwasher must be disconnected from the main power supply at the mains power switch, and the water intake tap must be closed.
- Abrasive or corrosive products, acids, solvents and chlorine-based detergents must **NOT** be used to clean the appliance, as this may damage the components.
- Detergents or sanitizers shall not be manually added to the machine.
- This appliance has been designed for use in ambient temperatures between 41 °F and 104 °F.
- Only the baskets, soaps and rinse aids recommended by the manufacturer should be used.





Failure to comply with these instructions or the incorrect use of the appliance shall relieve the manufacturer of any obligations regarding the guarantee or possible claims.

7. PRODUCT DETAILS

As it is an industrial product, it is characterised for having a high dishwashing capacity. The characteristics of the product are listed below to help you understand your machine better.

All the appliances have a nameplate which identifies the appliance and indicates its technical characteristics. This data plate is located on one side of the machine. Under no circumstances should the data plate be removed from the unit. The data plate is essential to identify the particular features of your machine and is of great benefit to installers, operators and maintenance personnel. It is recommended that, in the event the data plate is removed, you copy down the essential information in this manual for reference before installation.

DATA PLATE

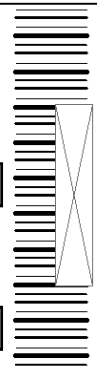
 FAGOR INDUSTRIAL S. COOP.		 Intertek		V Ph Hz kW A A		Made in EU 
MOD.	1	MOD N.	2	SERIAL N.	3	
				Water Inlet Max. Temperature 140°F Water pressure: 15-25 psi IPX3		5

- | | |
|-------------------------------------|-------------------------------|
| 1: APPLIANCE MODEL NAME | 4: ELECTRICAL SPECIFICATIONS |
| 2: APPLIANCE REFERENCE | 5: WATER INLET SPECIFICATIONS |
| 3: SERIAL NUMBER + MANUFACTURE DATE | |

These details should be quoted when the technical service is called.

7.1 TECHNICAL SPECIFICATIONS

MODEL	RACKS PER HR.	DISHES PER HR.	GLASSES PER HR.	WASH TANK (gal)	GALLONS PER CYCLE	WATER INLET MAX. TEMP.	WATER INLET PRESSURE
COP-174W HRS	34	850	1224	8.7	0.53	77 °F	At Water Inlet 15 – 58 psi
COP-174W	60	1500	2160	8.7	0.53	140 °F	
COP-504W	40	925	1332	5.4	0.53		
CO-502W	40	750	1080	5.4	0.53		
CO-500W	30	700	1008	5.4	0.53		
CO-402W	40	242	352	4	0.53		At Pressure Gauge 25psi ± 5psi
CO-400W	30	242	352	4	0.53		

MODEL	WASH PUMP MOTOR	MIN. TEMP.		HEATING ELEMENTS		OPERATING CYCLE TIME (s)				
		WASH	RINSE	WASH TANK (kW)	BOILER (kW)	WASH	DWELL	RINSE	HRS	TOTAL
COP-174W HRS	1 hp	156°F	180°F	4.9/3.25	13.1/8.7	39/59/104/584	5	11	50	105/125/170/650
COP-174W	1 hp	156°F	180°F	4.9/3.25	13.1/8.7	39/59/104/584	5	11	-	55/75/120/600
COP-504W	3/4 hp	156°F	180°F	3	6.1/4.1/3	74/104/164	5	11	-	90/120/180
CO-502W	3/4 hp	156°F	180°F	3	3	71/101/161	5	14	-	90/120/180
CO-500W	3/4 hp	156°F	180°F	3	3	101	5	14	-	120
CO-402W	1/3 hp	156°F	180°F	2.15	3	71/101/161	5	14	-	90/120/180
CO-400W	1/3 hp	156°F	180°F	2.15	3	101	5	14	-	120

MODEL	WIDTH	DEPTH	HEIGT	MAX CLEARANCE FOR DISHWARE	RACK
COP-174W HRS	24 3/4"	29 1/2"	75 1/2"	17"	20" x 20"
COP-174W	24 3/4"	29 1/2"	57 2/3"	17"	20 x 20"
COP-504W	23 5/8"	23 5/8"	32 11/16"	14 3/16"	20" x 20"
CO-502W					
CO-500W	20 7/8"	26 3/4"	35	10 5/8"	16" x 16"
CO-402W					
CO-400W					

HOOD TYPE DISHWASHERS

MODEL	CONNECTION TYPE	Voltage (V)	Total Load (A)	Total Power (kW)	Pump Load (A)	Pump Power (kW)	Tank Power (kW)	Boiler Power (kW)
COP-174W COP-174W HRS Full Power	208-240V 60Hz 3Ph	208V	40,33	14,09	2,87	0,60	3,68	9,81
		220V	42,65	15,76	3,04	0,67	4,12	10,98
		240V	46,53	18,76	3,31	0,79	4,90	13,07
COP-174W COP-174W HRS Boiler & Tank 2/3 Power	208-240V 60Hz 1Ph	208V	46,12	9,59	2,87	0,60	2,45	6,54
		220V	48,78	10,73	3,04	0,67	2,74	7,32
		240V	53,22	12,77	3,31	0,79	3,27	8,71

UNDERCOUNTER DISHWASHERS

MODEL	CONNECTION TYPE	Voltage (V)	Total Load (A)	Total Power (kW)	Pump Load (A)	Pump Power (kW)	Tank Power (kW)	Boiler Power (kW)
CO-502W COP-504W Full Power	208-240V 60Hz 3Ph	208V	15,03	5,06	2,36	0,48	2,29	4,58
		220V	15,9	5,66	2,50	0,54	2,56	5,12
		240V	17,35	6,74	2,72	0,64	3,05	6,10
CO-502W COP-504W Full Power	208-240V 60Hz 1Ph	208V	24,34	5,06	2,36	0,48	2,29	4,58
		220V	25,74	5,66	2,50	0,54	2,56	5,12
		240V	28,08	6,74	2,72	0,64	3,05	6,10
CO-502W COP-504W Boiler 2/3 Power	208-240V 60Hz 1Ph	208V	17	3,54	2,36	0,48	2,29	3,05
		220V	17,98	3,96	2,50	0,54	2,56	3,42
		240V	19,61	4,71	2,72	0,64	3,05	4,07
CO-502W COP-504W Boiler Half Power	208-240V 60Hz 1Ph	208V	13,33	2,77	2,36	0,48	2,29	2,29
		220V	14,1	3,1	2,50	0,54	2,56	2,56
		240V	15,38	3,69	2,72	0,64	3,05	3,05
CO-500W	208-240V 60Hz 1Ph	208V	13,33	2,77	2,36	0,48	2,29	2,29
		220V	14,1	3,1	2,50	0,54	2,56	2,56
		240V	15,38	3,69	2,72	0,64	3,05	3,05

GLASSWASHERS

MODEL	CONNECTION TYPE	Voltage (V)	Total Load (A)	Total Power (kW)	Pump Load (A)	Pump Power (kW)	Tank Power (kW)	Boiler Power (kW)
CO-400W CO-402W	208-240V 60Hz 1Ph	208V	12,03	2,50	1,02	0,21	1,64	2,29
		220V	12,73	2,80	1,08	0,24	1,83	2,56
		240V	13,88	3,33	1,18	0,28	2,18	3,05

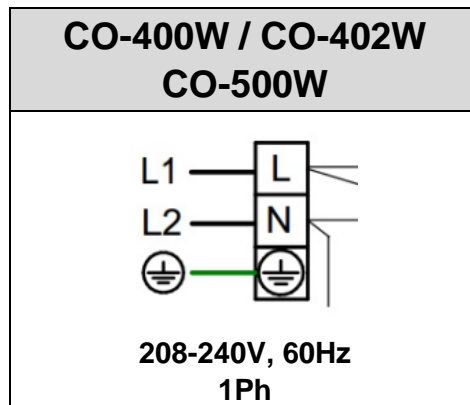
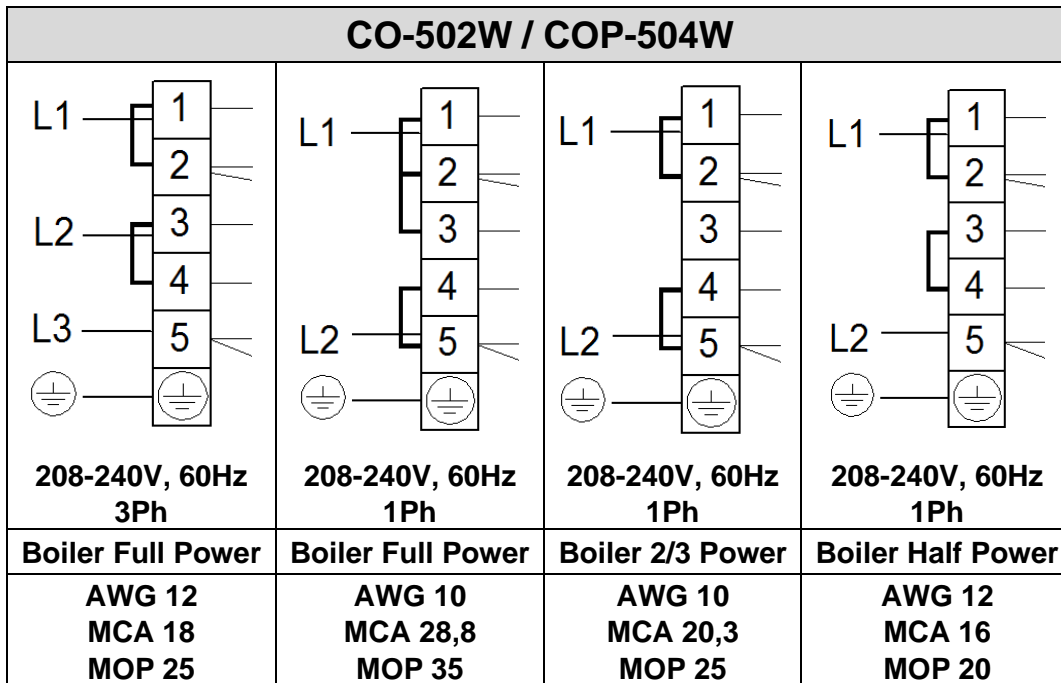
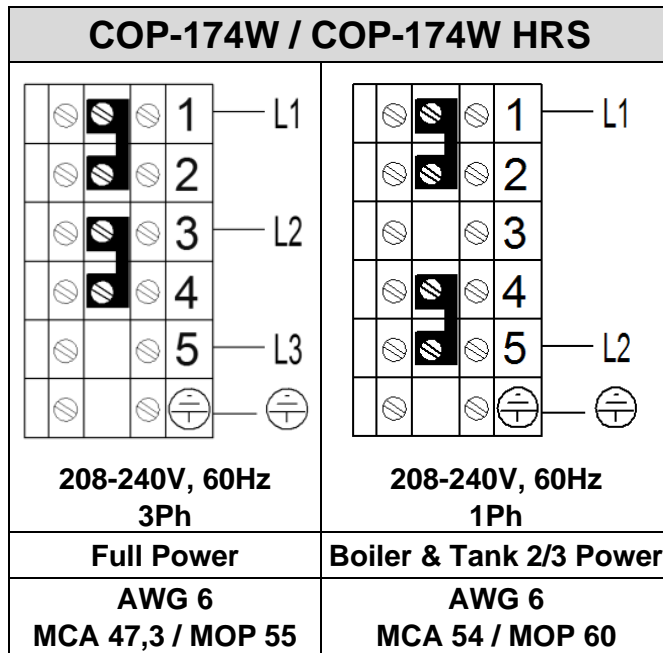

8. INSTALLATION INSTRUCTIONS



The dishwasher shall be installed in accordance with local codes, or in the absence of local codes, installed in accordance with the applicable requirements in the National Electrical Code, NFPA 70, Canadian Electrical Code (CEC), Part 1, CSA C22.1, and Standard for Ventilation Control and Fire Protection of Commercial Cooking Operations, NFPA 96.



The positioning and installation, and all repairs or modifications, should always be carried out by an **AUTHORISED TECHNICIAN**, in accordance with the applicable legislation of the country.

The installation, incorrect adjustment, inappropriate maintenance or use of the appliance may cause material damages and injuries.

8.1 Removal of packaging

Remove packaging from the machine and check for damage during transportation. If any damage is observed, immediately notify the supplier and the transport company. In the event of doubt, do not use the machine until the problem has been assessed.



Packaging (plastic, expanded polyurethane, staples, etc...) must not be left in the reach of children, they are a potential hazard.

The machine should be moved using a fork-lift truck or similar to avoid damage to the structure. Transport the machine to the installation location and then remove packaging. All the packaging can be recycled. Dispose of packaging correctly.

8.2 Positioning and levelling

This appliance has adjustable feet. This is done by turning the leveling stands to the desire height. For optimum operation, it is essential that the machine is correctly levelled. The flooring on which the machine is to be installed must be able to bear the full weight of the machine.

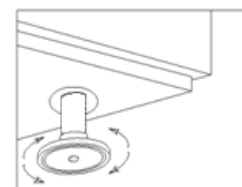
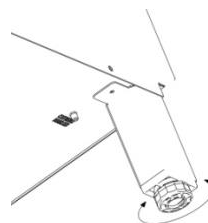

Inspect final location of the machine prior to installation to prevent damage during use.

8.3 Electrical connection



An AUTHORISED TECHNICIAN should always carry out the appliance's electrical connection.

The dishwasher shall be installed in accordance with local codes, or in the absence of local codes, installed in accordance with the applicable requirements in the National Electrical Code, NFPA 70, Canadian Electrical Code (CEC), Part 1, CSA C22.1, and Standard for Ventilation Control and Fire Protection of Commercial Cooking Operations, NFPA 96."



THIS APPLIANCE, WHEN INSTALLED, MUST BE ELECTRICALLY GROUNDED

The manufacturer cannot accept any responsibility for damage caused from a failure to observe grounding instructions.



- Refer to the wiring diagram, the machine data plate and technical specifications for service size requirements.
- Check that the mains voltage corresponds to that indicated on the nameplate.
- The power-supply cord shall be Type S, SE, SO, SOO, ST, STO, or STOO (with or without W at the end).
- The power supply cord wire size must be suitable for the rated current of the machine (amperage load). Use copper conductors only.
- The appliance must be grounded using the ground connection of the terminal block of the appliance.
- An all phase Circuit Breaker must be installed near to the appliance between the power supply and the appliance in accordance to required consumption guidelines. Switch the circuit breaker to “OFF” when servicing the appliance. It is recommended that it has lockout-tagout capabilities. The manufacturer will not be held liable for damage originated by failure to observe this requirement.
- A suitable safety switch / Residual current device must be installed near the appliance between the power supply and the appliance. The manufacturer will not be held liable for damage originated by failure to observe this requirement.
- If any faults are observed during the installation, the supplier should be notified immediately.

When a number of appliances are installed in line, they should all be ground bonded at the point provided for that purpose.

To access the connection strip when a permanent connection needs to be made, release the cover of the machine’s front (see chapter 2. General measurements and connections). The power cable is connected to the connection strip. It is also possible to change the machine configuration here.



The manufacturer will not be held liable for any personal or material damage to the machine resulting from incorrect installation or failure to comply with the manufacturer’s specifications.



It is the personal responsibility and obligation of the customer to contact a qualified electrician to assure that the electrical installation is adequate.

8.4 Hydraulic connection

The new hoses supplied with the appliance should be used (do not reuse old hoses).

Before connecting the machine to the water supply, the water quality should be tested.

Recommended water quality:

pH:	6.5 to 7.5
Free Chlorine:	Less than 0.2 ppm (mg/L)
Chlorides:	Less than 30 ppm (mg/L)
Hardness:	Less than 3 gpg (52 ppm)
Conductivity:	400 – 1.000 µS/cm
Silica:	Less than 12 ppm (mg/L)

Alkalinity:	Less than 50 ppm (mg/L)
Total Dissolved Solids (TDS):	Less than 60 ppm
Sulfates:	Less than 40 ppm
Iron:	Less than 0.1 ppm
Copper:	Less than 0.05 ppm
Manganese:	Less than 0.05 ppm

Water installation is carried out as shown in **Fig. 1**:

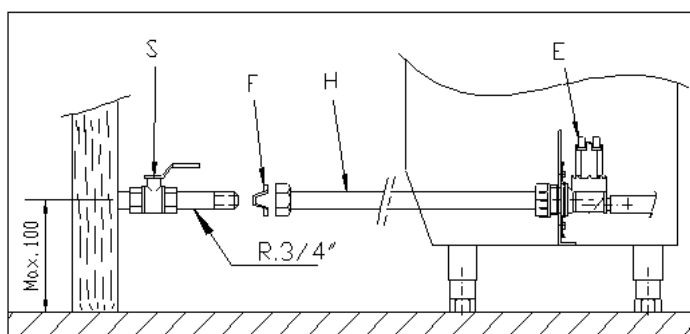

- S** → SHUT-OFF COCK
- F** → FILTER
- H** → WATER HOSE
- E** → WATER VALVE

Fig. 1. Direct connection of water input hose.

Use 3/4" copper tubing inlet line.

It is necessary to remove all foreign debris from the water line that may potentially get trapped in the valves or cause an obstruction, prior to connecting to the machine.

Use only the supplied hoses (3/4" Female hose connector) at the water connections. Failure to do so may result in damage to the solenoid valve threads and leaking. Tighten by hand. Connect the bent side of the hose to the machine. Adaptor supplied for 3/4" female garden hose connection.

FOR HARD WATER SUPPLIES WITH A HARDNESS OF OVER 3 gpg OR 5°fH AND PH BEYOND THE RANGE OF 6.5 – 7.5, A WATER CONDITIONER/DESCALER MUST BE INSTALLED.

In addition to water quality, the pressure of the mains water supply must be considered. This is important to ensure the machine operates correctly.

CO models: Required water dynamic pressure measured at pressure gauge 25psi ± 5psi.

COP models: Required water dynamic pressure measured at water inlet between 20-58 psi.

CAUTION: Do not confuse static pressure with flow pressure. Static pressure is the line pressure in a "no flow" condition (all valves and services are closed). Flow pressure is the pressure in the fill line when the solenoid valve is opened during the filling or cycle.

In areas where the pressure fluctuates or it is higher than the recommended pressure, a water pressure regulator shall be installed between the shut-off cock and the water hose (**Fig. 1.**).

If the water pressure is less than required, installation of a water pump is required.

The hot water heater should be set to deliver 140 °F (not lower than 122 °F) water temperature to the dishwasher for best results, except in hood type HRS models, where the water inlet temperature should be between 41 °F and 77 °F in order for the HRS system to function properly.

Slowly turn on the water supply to the machine after the incoming fill line and the drain line have been installed. Check for any leaks and repair as required. All leaks must be repaired prior to placing the machine in operation.

The following requirements are necessary for the correct hydraulic installation of the machine.

- The hydraulic circuit must be fitted with a valve to shut-off the water supply.
- Check that the mains pressure is within the range indicated.
- To optimise the work of the machine, the water temperature at the machine intake should be within the following range: 122 °F (50 °C) < Hot water Temp < 140 °F (60 °C)
For HRS hood type models: 41 °F (5 °C) < Water Temp (HRS) < 77 °F (25 °C).
- If using hot water, the water temperature must not exceed 60 °C / 140 °F.
- All the machines should have a 3/4" screw-on connection.

8.5 Drainage connection

Attach the drain hose as shown in Fig. 2. The drainage pipe must always be fitted on a siphon to prevent the return of odours.

All piping from the machine to the drain must be a minimum 1-1/2" I.P.S. There should also be an air gap between the machine drain line and the drain. For natural overflow efficiency use floor drain.

The water draining from the machine must flow freely and therefore the drainage pipe should be lower than the drainage outlet (**Fig. 2**).

If the drainage pipe is not lower, a drainage pump will be required. This must not be mounted at a height of more than **23 5/8"** for hood type dishwashers or **19 3/4"** for undercounter dishwashers and glasswashers (**Fig. 3**). In this case, the pump may be requested at the time of purchase or subsequently.

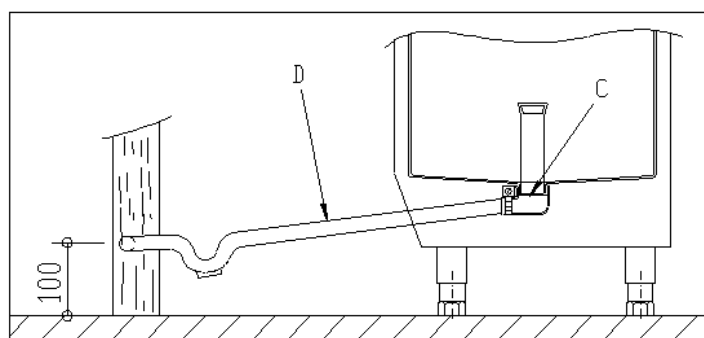

D: Drain hose
C: Drain collector

Fig. 2. Drainage installation.

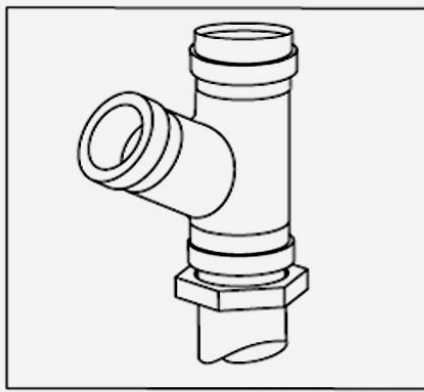

The dishwasher flexible drain hose must be connected to a WYE fitting.

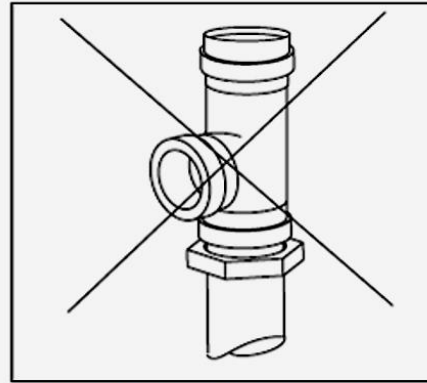

Do not connect the dishwasher flexible drain hose to a TEE fitting.

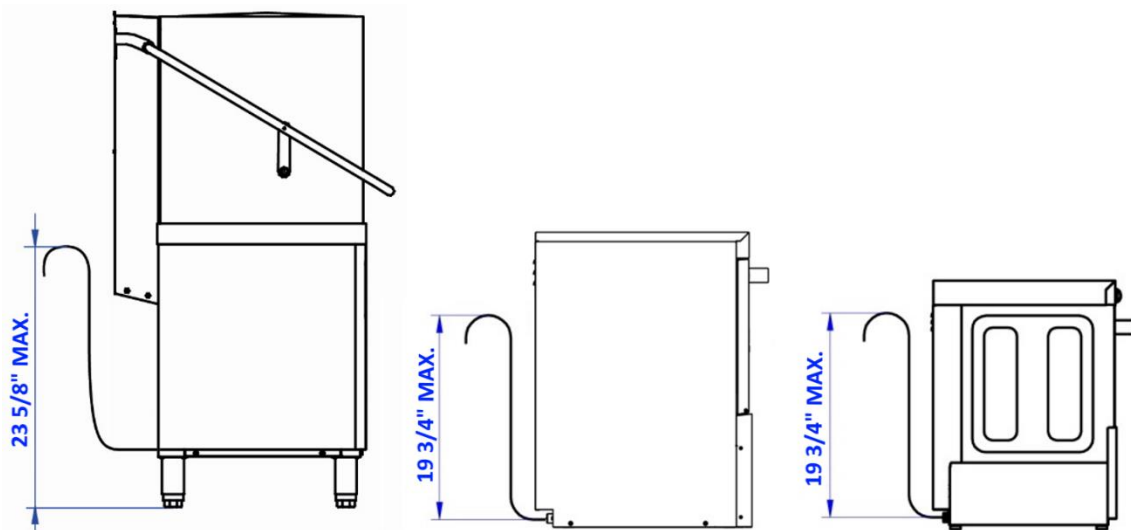

Fig. 3. Installation of drainage at a height using drainage pump.



The drainage pump must only be installed by personnel authorised by the manufacturer, and the manufacturer does not accept liability in the event of incorrect installation.

8.6 Hydraulic rinse aid dispenser (CO MODELS)

Installation: Take the tube located in the back of your machine marked “Rinse Aid” and place inside rinse container.

Tubes are transparent to provide you visible mean that chemicals are being dispensed.

Operation: This dispenser absorbs the rinse aid when it detects a loss in pressure during rinsing. That is, when the filling solenoid valve closes, a vacuum is created that makes the rinse aid dispenser absorb the fluid to which it is connected.

Adjustment: The dispenser should be adjusted when the machine is installed to ensure that the wash is optimised from the start. The setting should be adjusted according to the type of rinse aid and the water hardness.

WATER PRESSURE MUST BE MINIMUM 20 PSI AT THE PRESSURE GAUGE FOR THE RINSE AID DISPENSER TO OPERATE PROPERLY.

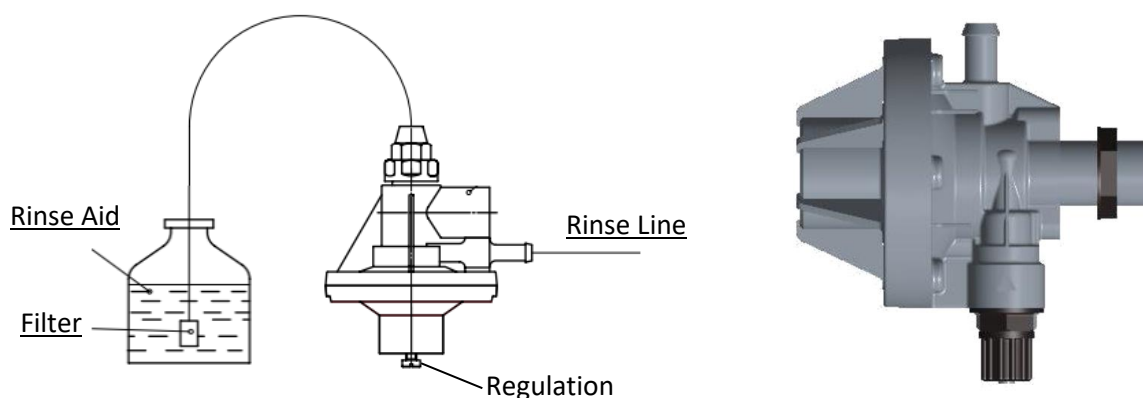

8.7 Electric rinse aid dispenser (COP MODELS)

Installation: Take the tube located in the back of your machine marked “Rinse Aid” and place inside rinse container.

Tubes are transparent to provide you visible mean that chemicals are being dispensed.

Operation: this dispenser absorbs the rinse aid when the rinse pump is switched on. That is, when the machine is filling and when the machine is running the rinse cycle.

Adjustment: The dispenser should be adjusted when the machine is installed to ensure that the wash is optimised from the start. The setting should be adjusted according to the type of rinse aid and the water hardness.

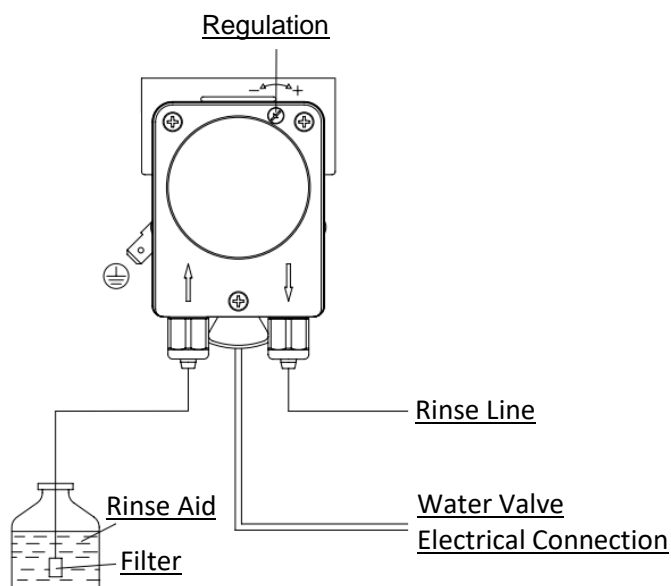

In order to maintain dishwasher at optimum conditions, it is requested to remove lime and corrosion deposits on a frequent basis. A de-liming solution should be available from your chemical supplier. Read and follow all instructions on the label of the de-liming solution. Operations:

- Fill the machine. Add the correct amount of de-liming solutions as recommended by the de-liming solution manufacturer. The water capacity of the tank can be verified on the specification sheet of this manual.
- Remove detergent and rinsing tubes from containers so no chemicals go to the machine.
- Run the machine for the recommended period of time. As many cycles as needed.
- Turn off the machine and open the door.
- When clean, drain and re-fill the machine.
- Run machine for 3-4 cycles to remove de-liming solution.
- Drain the machine.

If desired, you can control the amount of Chemical being dispensed by opening the bottom front panel of the machine. Locate the detergent dispenser and regulate according to the flow. For the Rinse, turn the button counterclockwise to get more rinse aide and clockwise for less. Verify all connections to the dispenser are hand tighten to prevent any leaks.

Control and maintain the level of detergent and rinse aid of the tanks. Keep chemical tubing and filters submerged.



It is recommended that the rinse aid product and the dispenser setting are defined by a technician specialised in the use of chemical products in order to ensure a more efficient wash.

8.8 Detergent dispenser

This machine must be operated with an automatic detergent feeder including a visual means to verify that detergent is delivered or a visual or audible alarm to signal if detergent is not available for delivery to the respective washing system. Please see instructions for electrical and plumbing connections located in this manual and in the feeder equipment manual.

The detergent dispenser ensures that the correct measure of detergent is supplied to the machine.

Use **ONLY Commercial Grade, High Temperature, Low Suds Liquid Detergent**. Fagor doesn't recommend any specific brand name of chemicals. Contact your local chemical distributor for questions concerning your chemical needs.

Installation: the detergent dispenser input is in the wash tank front part, above the maximum water level.

Take the tube located in the back of your machine marked "Detergent" and place inside detergent container.

Tubes are transparent to provide you visible means that chemicals are being dispensed.

Operation: the detergent dispenser is activated when the machine is taking water, whether it is in rinse cycle or whether it is filling.

Settings: the quantity of detergent used should be adjusted on installation to ensure that the wash is optimised from the start.

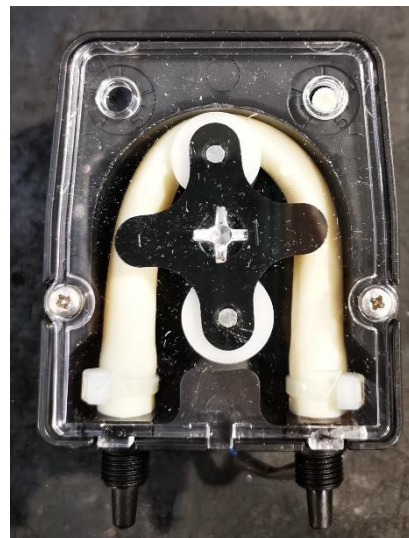
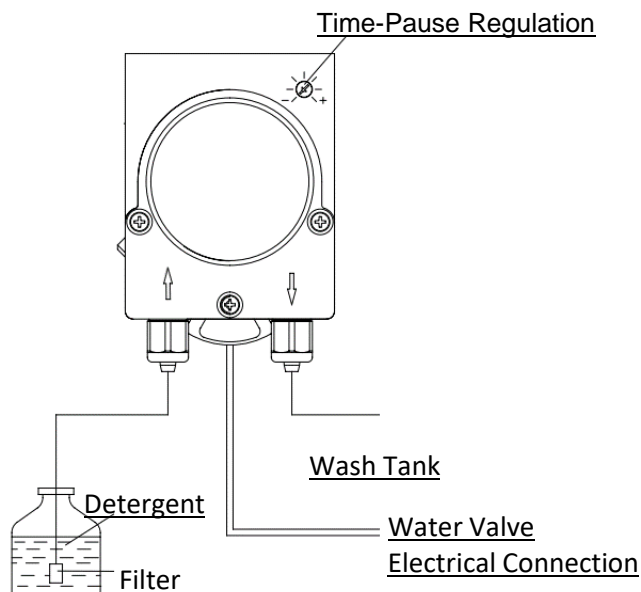

It is recommended that the detergent and the dispenser setting are defined by a technician specialised in the use of chemical products in order to ensure a more efficient wash.



If you require the installation of a NON FAGOR Detergent and/or Rinse pump, a form MUST be fill out prior to installation by your installer. Failure to do so will void your Warranty. This form can be located inside your dishwasher. If lost, please contact Fagor to get a copy.



The detergent pump and rinse dispensing pump will only work during the process of fill and rinse.

8.9 Recycling

The product packaging consists of:

- A wooden pallet.
- Cardboard.
- A polypropylene band.
- Expanded polyethylene.



All the packaging used around the machine can be recycled. The correct disposal of these products will help to protect the environment. For further information regarding the recycling of these products, please refer to the relevant office of the local body. Dispose of these materials in accordance with current legislation.

9. USE AND MAINTENANCE INSTRUCTIONS



BEFORE STARTING THE APPLIANCE, PLEASE READ THE INSTRUCTIONS CONTAINED IN THIS MANUAL CAREFULLY.



THE APPLIANCE IS EXCLUSIVELY FOR PROFESSIONAL USE AND SHOULD ONLY BE USED BY QUALIFIED PERSONNEL.

9.1 Operation

The steps required to optimise the operation of your dishwasher are shown below, with all the available options.

9.1.1 Control panel symbols

CO-400W (Glasswasher)

CO-500W (Front Loading Dishwasher)

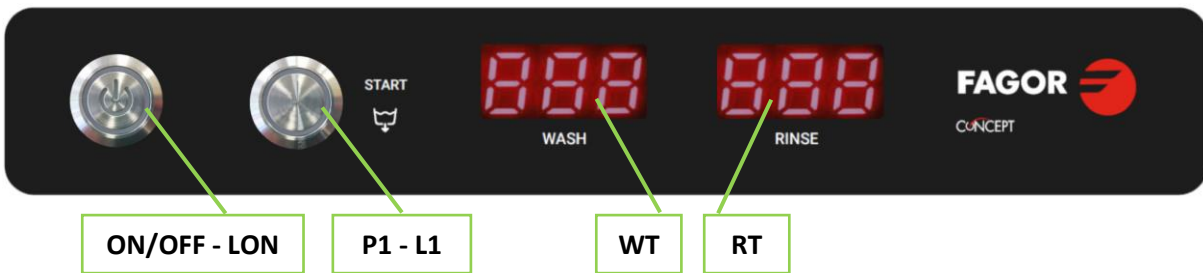

CO-402W (Glasswasher)

CO-502W / COP-504W (Front Loading Dishwasher)

COP-174W / COP-174W HRS (Hood Type Dishwasher)

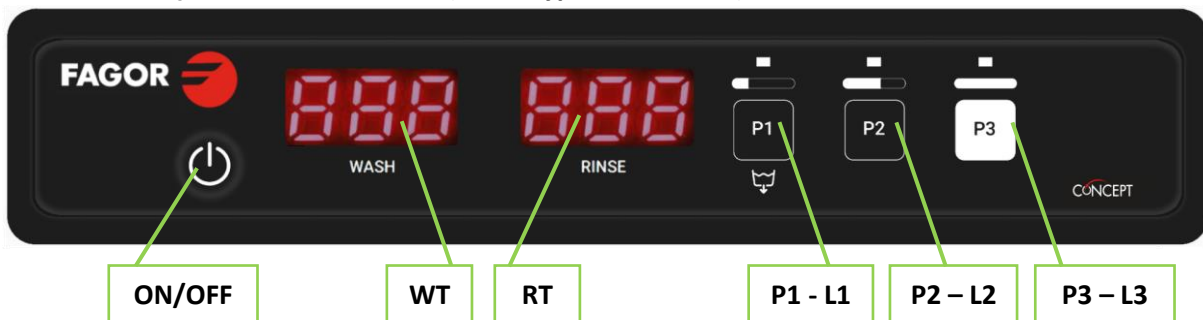

ON/OFF	ON/OFF Button
P1	Wash Cycle 1 / Drainage Button
P2	Wash Cycle 2 Button
P3	Wash Cycle 3 Button Wash Cycle 4 Button on Hood Type (Long pressing 3 seconds)

LON	ON/OFF Pilot Light
WT	Wash Tub thermometer
RT	Rinse boiler thermometer
L1 / L2 / L3	Blinking: Cycle pilot light Steady: Machine Ready

9.1.2 Switching on the machine

Before switching on the machine, check the following:

- ✓ The mains switch must be on.
- ✓ The water stop cock must be open.
- ✓ There must be water in the mains network.
- ✓ The corresponding filters must be in place.
- ✓ The overflow should be mounted in place.

To switch on the machine just press the *ON-OFF* button once for 2 seconds.

9.1.2.1 Filling and heating

In the CO models, when the machine is switched on, it will start to fill the machine. First the rinse boiler is filled and then the wash tub. The filling process may last a few minutes. Once the wash tub is full, the boiler and the tub start to heat up. Although it is possible to start the wash process, this is not recommended as the water inside the machine is not yet at the ideal temperature. When the machine has reached the ideal temperature for washing the dishes properly, a light comes on, advising the user that the machine is ready. The required temperature of the machine is over 180 °F in the rinse boiler (see thermo-stop chapter) and over 158 °F in the wash tub. It is recommended that the water in the dishwasher is changed every 40/50 washes or twice a day.

In the COP models, the filling is thermostatic. This means that when the water boiler is full, the boiler heats the water and then the tank is filled. This process is repeated each time the boiler is emptied during the filling cycle. This filling system is more efficient and helps reducing the filling time.



The hood/door must be closed for the machine to start filling. For safety reasons, if the hood/door is open, the machine will not fill.

The machine you have purchased has a safety thermostat in the boiler and another for the tub, so that in the event of the breakdown of any of the main thermostats, the safety thermostats switch off the corresponding heating.



During the first heating of the day, the boiler may reach a higher temperature than that mentioned above due to heating inertia. This is normal. If pressurised steam is observed coming out of the rinse branch nozzles, while the boiler is heating, the technical service should be notified.

9.1.3 Hygiene practices

- Operators must strictly observe all hygiene requirements when handling clean dishes and cutlery.
- Do not touch clean dishes with dirty or greasy hands. Handle the dishes/cutlery with gloves or clean hands to prevent contamination. Be careful as the dishes will be hot.
- Use clean sterilised cloths to thoroughly dry the dishes. Do not dry the plates with kitchen towels or cloths that are not sterile.
- Wait until the machine reaches the correct wash temperature to ensure a thorough disinfection and wash. To obtain optimum results wash the dishes when the machine is ready.
- Drain the wash tub and rinse the filters at least twice a day or every 40-50 wash cycles.
- Make sure that the quantities of detergent and rinse aid dispensed are correct (as recommended by supplier). At the start of the work day, check that the quantity of product in the reservoirs is enough for the daily requirement.
- The dishwasher should be kept perfectly clean and maintained.

9.1.4 Preparation of the dishes

Before washing the dishes, the preparatory steps below should be followed:

- Remove the largest pieces of waste from the dishes before placing them in the baskets to avoid blocking the filters, nozzles and tubes.
- Wash glassware first.
- Put the plates in the rack basket.
- Place the glasses upside down.
- Place the cutlery in the cutlery baskets with the handles downwards. The different pieces of cutlery can be mixed.
- Place the cutlery baskets in the lower baskets.



9.1.5 Selecting the wash cycle

Before starting the wash cycle, place the corresponding basket containing the dishes in the machine and close the hood/door.



Before starting the wash cycle, the machine should have the ideal temperature for washing the dishes properly, indicated by the selected/default program led switched on and the temperature on thermometers, advising the user that the machine is ready. The required temperature of the machine is over 180 °F (see thermo-stop chapter) in the rinse boiler and over 158 °F in the wash tub.

In glasswashers and undercounter dishwashers, to start the wash cycle, a wash cycle button must be pressed (P1/P2/P3) with the door closed.

In the hood type dishwashers, the last used (or default at start) wash cycle starts automatically when the hood is closed. The cycle can be selected with the hood open. Also, a wash cycle button can be pressed (P1/P2/P3/P3-Long press 3s) with the hood closed in order to start the wash cycle.

The wash cycle selected by default is P2 in machines with more than one wash cycle button. Each wash cycle corresponds to a wash time that should be selected according to the user requirements.

When the wash cycle starts, the selected program led will switch on blinking.

	The hood/door must be closed for the machine to start the wash cycle. For safety reasons, if the hood/door is open, the wash cycle will not start.
	If you start your dishwasher prior to your boiler reaching a minimum of 180°F (83 °C), YOU WILL HAVE AN EXTENDED WASH CYCLE!

Wash cycle times:

		P1	P2	P3	P3 (3s) – Extended (Only Hood Type)
GLASSWASHER	CO-400W	120s	-	-	-
	CO-402W	90s	120s	180s	-
UNDERCOUNTER DISHWASHER	CO-500W	120s	-	-	-
	CO-502W	90s	120s	180s	-
	COP-504W	90s	120s	180s	-
HOOD TYPE DISHWASHER	COP-174W	55s	75s	120s	600s
	COP-174W HRS	105s (50s HRS)	125s (50s HRS)	170s (50s HRS)	650s (50s HRS)

9.1.5.1 Thermo-stop

The thermo-stop is designed to ensure a constant rinse at the maximum temperature. This means that the machine continues washing until the boiler reaches the ideal temperature. Then the rinse cycle starts.

	If the mains water temperature is less than 50 °C / 122 °F, the wash capacity may be reduced.
---	--

9.1.5.2 Hood type HRS models

The HRS hood type dishwashers integrate the HRS system, which recycles steam energy to heat incoming water and keeps steam out when opening the hood.

When the cycle finishes, the HRS system works for another 50 seconds, indicated in the thermometers by flashing "HrS" or by the cycle light.

If the hood is opened before finishing the HRS cycle stops completely, but in that case the steam may not be completely eliminated.

The HRS system working time can be reduced, please contact an Authorised technician.

9.1.6 Stopping the wash cycle and end of wash cycle

The wash cycle can be stopped or paused in the following ways:

- By pressing again the active cycle button → the cycle stops completely.
- By opening the hood/door → Cycle pause. When the hood/door is closed, the cycle continues.
- By switching off the machine → the cycle stops completely.

At the end of the wash cycle, remove the basket and leave the dishes to dry naturally. Remove the dishes from the basket with clean hands, taking care not to burn yourself as the dishes are extremely hot.

9.1.7 Drainage of the machine

The dishwashers have two types of drainage; gravity drainage or using a drainage pump, which is optional.

9.1.7.1 Drainage by gravity

To drain the machine in this way first switch off the machine, then just remove the overflow tube from the machine and it will drain naturally. For safety reasons, this drainage method should only be used with the machine switched off.

- Switch off the machine. Press ON/OFF button for 3 seconds to turn unit OFF.
- Open the hood/door and remove the filter tray. (Fig. 4)
- Remove the overflow tube. (Fig. 5)
- Wait until the tub is empty. Clean any dirt that could be on the bottom of the tub.
- Take out scrap basket for cleaning by twisting to the left. (Fig. 6)
- Replace scrap basket, lock into position by twisting to the right and replace overflow tube with O-ring.
- Replace filter tray back into position (Fig. 4).
- Wipe clean and dry the machine if the day is completed. Leave door open until the next day's operations or to one of the time settings to begin using the machine again.
- To avoid the risk of damage from oxidization or corrosion from chemicals, keep all steel surfaces clean.

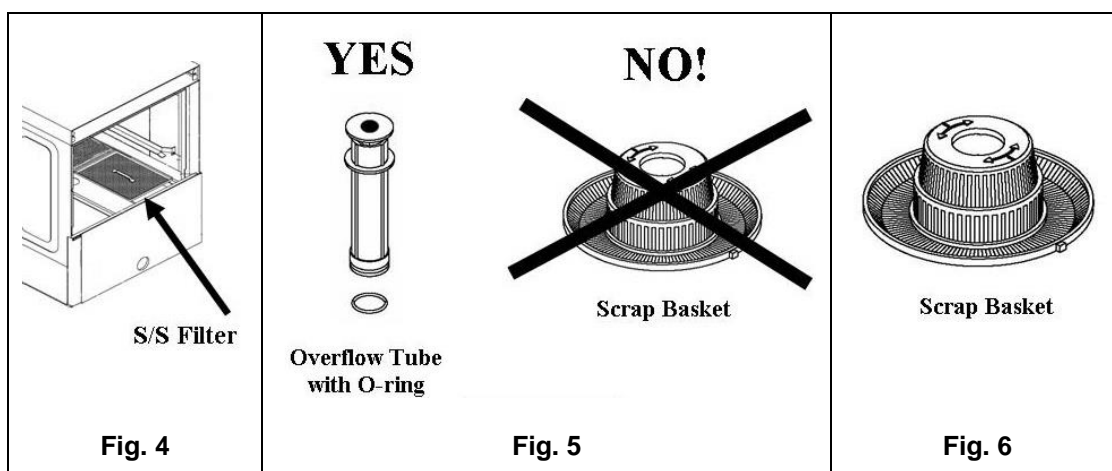

9.1.7.2 Drainage using the drainage pump (Optional)

The drainage using the drainage pump option is only available on request. To drain the machine using this method, proceed as follows:

- Open the hood/door and remove the filter tray. (Fig. 4)
- Remove the overflow tube. (Fig. 5)
- With the hood/door open, press the button P1 for 3 seconds, L1 will blink during operation.
- Wait until the led turns off.
- At the end of the drain cycle, the machine will be automatically switched off.
- Clean any dirt that could be on the bottom of the tub.
- Take out scrap basket for cleaning by twisting to the left. (Fig. 6)
- Replace scrap basket, lock into position by twisting to the right and replace overflow tube with O-ring.
- Replace filter tray back into position (Fig. 4).
- Press ON/OFF button to turn unit OFF.
- Wipe clean and dry the machine if the day is completed. Leave door open until the next day's operations or to one of the time settings to begin using the machine again.
- To avoid the risk of damage from oxidization or corrosion from chemicals, keep all steel surfaces clean.



To drain the machine with the drainage pump, the hose must be at a height (max. 23 5/8" in hood type dishwashers or 19 3/4" in undercounter dishwashers and glasswashers).

9.1.8 Switching off the machine

To switch off the machine, just press the *ON/OFF* button once for 3 seconds.

The machine should not be switched off during the wash process as this will stop the tableware inside the machine from being cleaned properly.

9.1.9 Cleaning the machine at the end of the day

At the end of the day, the filters, wash distributors, rinse branches and other accessories must be cleaned. This is necessary to prolong the service life of the machine.

To ensure the efficient washing of the dishes, the dishwasher must be perfectly clean and disinfected.

9.2 Cleaning and Maintenance Instructions

9.2.1 Routine maintenance

Every day at the end of the day, the filters, wash distributors, rinse branches and other accessories must be cleaned.

To ensure the efficient washing of the dishes, the dishwasher must be perfectly clean and disinfected.

Always clean the machine correctly to prolong the service life of the machine.

- Remove any waste from the machine at the end of each day.
- Do not use abrasive, corrosive or acid products, chlorine-based detergents, solvents or petrol derivatives to clean the machine.
- Do not use pressurised water to clean the machine.
- Do not spray off the machine and the immediate vicinity (walls, floors) with a water hose, steam cleaner or pressure washer.
- In order to prevent water from entering into the machine uncontrolledly, make sure that the machine's plinth is not flooded when cleaning the floor.
- Only wash tableware, glassware or kitchenware that has been used for human food.
- Check that the wash distributors rotate correctly every day.
- Check the rinse aid and detergent levels at the start of each day.
- If the power cable is damaged, it must be replaced by the manufacturer, after-sales service or authorised technical personnel in order to prevent risks.

9.2.2 Rinse aid and detergent

If you change the rinse aid or detergent, the settings should be adjusted accordingly. This adjustment must be carried out by qualified personnel. Only use detergents suitable for industrial dishwashers. Do not use foam-producing detergents. Detergents designed for domestic use should not be used under any circumstances.



When handling chemical substances, the safety instructions must be observed. Use suitable protective clothing, gloves and safety goggles when handling chemical substances. Do not mix different detergents.

9.2.3 Prolonged non use

If the machine is kept out of service for a long period of time (holidays, temporary closure...), please observe the following:

- Drain the machine completely, including the boiler.
- Clean the machine thoroughly.
- Leave the hood/door of the machine open.
- Close the water intake valve.
- Switch off the mains power supply.
- If there is a risk of frosts, ask your technical service to protect the machine against frosts.

10. FAULTS, ALARMS AND BREAKDOWNS

The steps to be followed in the event of a fault or operating error are described below. The possible causes and possible solutions are listed in the following table. In the event of doubt, or if you are unable to resolve the problem, please contact the technical service.



Do not handle electrical components, as there is a risk of death as the components are live.

FAULT	POSSIBLE CAUSE	SOLUTION
The machine does not come on.	There is no power supply.	Check whether the magneto-thermal circuit breaker has been triggered.
	The fuses have blown.	Call the technical service to analyse the reason why.
	Main switch open.	Close switch.
The machine does not fill with water.	Water entrance valve closed.	Open the water valve.
	Rinse nozzles blocked.	Clean nozzles and check branches for build-up of lime.
	Solenoid valve filter blocked.	Call the technical service to clean the filter.
	Rinse pump faulty.	Call the technical service to replace the pressure switch.
	Pressure switch is broken.	Call the technical service to replace the pressure switch.









FAULT	POSSIBLE CAUSE	SOLUTION
Unsatisfactory wash.	Wash distributors obstructed.	Clean distributors thoroughly.
	Shortage of detergent.	Call the technical service to reset the dispenser.
	Dirty filters.	Clean the filters thoroughly.
	Presence of foam.	Unsuitable detergent. Call the technical service to supply correct detergent.
		Too much rinse aid. Call the technical service to reset the dispenser.
	Temperature of lower tub at 50 °C / 122 °F.	Thermostat faulty or incorrectly set. Call the technical service to repair it.
	Length of cycle too short for level of dirt on dishes.	Select a longer cycle.
Water too dirty.	Drain the wash tub and fill with clean water.	
Dishes and kitchenware are not dry.	There is no rinse aid	Fill the rinse aid container.
	Rinse aid low.	Call technical service to adjust dispenser.
	Dishes left inside dishwasher for too long.	When the dishwasher finishes, remove the basket from the machine and allow to dry naturally.
	Rinse temperature lower than 80 °C / 176 °F.	Call technical service to analyse problem.
Scratches or stains on dishes.	Too much rinse aid.	Call technical service to adjust rinse aid dispenser.
	Water too chalky.	Check water hardness.
Machine stops during operation.	Electrical installation overloaded.	Call technical service to modify electrical installation.
	Machine protection has tripped.	Reset safety device and if it trips again, call technical service.
Machine stops and fills with water when it is washing.	Pressure switch pipe blocked.	Empty the tub and clean thoroughly.
	Pressure switch faulty.	Call the technical service to replace it.
	Overflow incorrectly mounted.	Mount overflow correctly.
The machine does not start with the wash cycle.	Hood/door is not closed properly.	Close the hood/door correctly and if it is seen to re-open alone, call the technical services to adjust the tensioners.
	Hood/door micro switch faulty.	Call the technical service to replace it.
Machine does not drain completely.	Machine not levelled correctly.	Level the machine. In the event of doubt, please contact your technical service.
	Pressure switch faulty.	Call the technical service to replace the pressure switch.

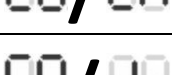

NOTE: If a fault occurs and is not listed in the above table, please call the technical service. The manufacturer reserves the right to modify the technical characteristics with prior warning.

10.1 Error diagnosis

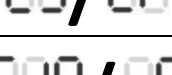
The errors and warnings are indicated in the thermometers display by the following codes:

ERROR IN DISPLAY	DESCRIPTION	CONSEQUENCE
	Faulty boiler temperature probe (Not detected or out of range [23°F-392°F]). (E1 / BP) E1 / Boiler Probe	Machine disabled.
	Faulty tank temperature probe (Not detected or out of range [23°F-392°F]). (E2 / TP) E2 / Tank Probe	Machine disabled.
	Boiler overheating (>210°F). (E3 / BO) E3 / Boiler Overheating	Machine disabled.
	Tank overheating(>197°F). (E4 / TO) E4 / Tank Overheating	Machine disabled.
	Boiler heating failure. (E5 / BH) E5 / Boiler Heating	WARNING on display.
	Tank heating failure. (E6 / TH) E6 / Tank Heating	WARNING on display.
	Draining error. After 2 minutes with drain cycle the level of the tank has not dropped (E7 / DR) E7 / Drain	Machine disabled.
	The boiler does not fill. After 8 minutes the boiler is not full. (E8 / BF) E8 / Boiler Filling	Machine disabled.
	The tank does not fill. (E9 / TF) E9 / Tank Filling	Machine disabled.
	Rinse error. The boiler level does not decrease during the rinse cycle. (E10 / RS) E10 / Rinse	Machine disabled.

All errors disappear when switching off the machine, but the error could appear again if it is not corrected.

WARNINGS:

DOOR WARNING IN DISPLAY	DESCRIPTION	CONSEQUENCE
	A cycle is trying to run with the door open.	WARNING on display 3 times.
	The door is open when filling the machine.	WARNING on display 3 times every minute until door is closed.



FAGOR COMMERCIAL

Fagor Commercial Inc.

13105 NW 47th Avenue

Miami, FL. 33054, USA

T. 305 779 0170

Fax. 305 779 0173

1-866-GO FAGOR

www.fagorcommercial.com