

# Contents

<b>1 Instructions</b>	<b>101</b>
1.1 General safety instructions	101
1.2 Manufacturer liability	105
1.3 Appliance purpose	106
1.4 Identification plate	106
1.5 This user manual	106
1.6 Disposal	106
1.7 How to read the user manual	107
<b>2 Description</b>	<b>108</b>
2.1 General Description	108
2.2 Control panel	109
2.3 Cooking hob	110
2.4 Other parts	110
2.5 Available accessories	111
<b>3 Use</b>	<b>113</b>
3.1 Instructions	113
3.2 Precautions	114
3.3 First use	114
3.4 Using the accessories	115
3.5 Using the hob	118
3.6 Using the storage compartment	119
3.7 Using the oven	120
3.8 Cooking advice	129
3.9 Special functions	130
3.10 Preset recipes	139
3.11 Personal recipes	149
3.12 Settings	155

EN

## TRANSLATION OF THE ORIGINAL INSTRUCTIONS

We advise you to read this manual carefully, which contains all the instructions for maintaining the appliance's aesthetic and functional qualities.

For further information on the product: [www.smeg.com](http://www.smeg.com)

# Contents

<b>4</b>	<b>Cleaning and maintenance</b>	<b>160</b>
4.1	Instructions	160
4.2	Cleaning the hob	160
4.3	Cleaning the oven cavity	161
4.4	Vapor Clean (on some models only)	165
4.5	Pyrolytic (on some models only)	168
4.6	Removing the door	172
4.7	Cleaning the door glazing	172
4.8	Extraordinary maintenance	175
<b>5</b>	<b>Installation</b>	<b>178</b>
5.1	Gas connection (not valid for the UK)	178
5.2	Positioning	188
5.3	Electrical connection	192
5.4	Instructions for the installer	194

We advise you to read this manual carefully, which contains all the instructions for maintaining the appliance's aesthetic and functional qualities.

For further information on the product: [www.smeg.com](http://www.smeg.com)



## 1 Instructions

### 1.1 General safety instructions

#### Risk of personal injury

- During use the appliance and its accessible parts become very hot. Never touch the heating elements during use.
- Protect your hands by wearing oven gloves when moving food inside the oven.
- Never try to put out a fire or flames with water: turn off the appliance and smother the flames with a fire blanket or other appropriate cover.
- This appliance may be used by children aged at least 8 and by people of reduced physical, sensory or mental capacity, or lacking in experience in the use of electrical appliances, provided that they are supervised or instructed by adults who are responsible for their safety.
- Children must not play with the appliance.
- Keep children under the age of 8 at a safe distance unless they are constantly supervised.
- Keep children under the age of 8 away from the appliance when it is in use.
- Cleaning and maintenance must not be carried out by unsupervised children.
- Make sure that the flame-spreader crowns are correctly positioned in their seats with their respective burner caps.
- Be aware of how rapidly the cooking zones heat up. Do not place empty pans on the heat. Danger of overheating.
- Fats and oils can catch fire if they overheat. Do not leave the appliance unattended while preparing foods containing oils or fats. If fats or oils catch fire, never put water on them. Place the lid on the pan and turn off the relevant cooking zone.
- The cooking process must always be monitored. A short cooking process must be continuously surveyed.



## Instructions

- While cooking do not place metal objects, such as cutlery or dishes on the hob surface as they may overheat.
- Do not insert pointed metal objects (cutlery or utensils) into the slots in the appliance.
- Do not pour water directly on very hot trays.
- Keep the oven door closed during cooking.
- If you need to move food or at the end of cooking, open the door 5 cm for a few seconds, let the steam come out, then open it fully.
- Do not open the storage compartment (where present) when the oven is on and still hot.
- The items inside the storage compartment could be very hot after using the oven.
- **DO NOT USE OR STORE FLAMMABLE MATERIALS IN THE STORAGE COMPARTMENT (IF AVAILABLE) OR NEAR THE APPLIANCE.**
- **DO NOT USE AEROSOLS IN THE VICINITY OF THIS APPLIANCE WHILST IT IS IN USE.**
- Switch off the appliance immediately after use.
- **DO NOT MODIFY THIS APPLIANCE.**
- Always use any necessary/required personal protective equipment (PPE) before performing any work on the appliance (installation, maintenance, positioning or movement).
- Before performing any operation on the appliance, switch off the power supply.
- Have qualified personnel carry out installation and assistance interventions according to the standards in force.
- Do not try to repair the appliance yourself or without the intervention of a qualified technician.
- Do not pull the cable to remove the plug.
- If the power supply cable is damaged, contact technical support immediately and they will replace it.



## Risk of damaging the appliance

- Do not use abrasive or corrosive detergents (e.g. scouring powders, stain removers and metallic sponges) on glass parts.
- Use wooden or plastic utensils.
- Racks and trays should be inserted as far as they will go into the side guides. The mechanical safety locks that prevent them from being removed must face downwards and towards the back of the oven cavity.
- Do not sit on the appliance.
- Do not use steam jets to clean the appliance.
- Do not obstruct ventilation openings and heat dispersal slots.
- Never leave the appliance unattended during cooking operations where fats or oils could be released, as these could then heat up and catch fire. Be very careful
- Never leave objects on the cooking surface.
- DO NOT USE THE APPLIANCE TO HEAT ROOMS FOR ANY REASON.
- Do not spray any spray products near the oven.
- Do not use plastic cookware or containers for cooking.
- Do not place sealed tins or containers in the oven cavity.
- Remove all trays and racks which are not required during cooking.
- Do not cover the bottom of the oven cavity with aluminium or tin foil sheets.
- Do not place pans or trays directly on the bottom of the oven cavity.
- If you wish to use greaseproof paper, place it so that it will not interfere with the hot air circulation inside the oven.
- Do not use the open door to place pans or trays on the internal glazing pane.
- Cooking vessels or griddle plates should be placed inside the perimeter of the hob.



## Instructions

- All pans must have smooth, flat bottoms.
- If any liquid does boil over or spill, remove the excess from the hob.
- Take care not to spill acid substances such as lemon juice or vinegar on the hob.
- Do not put empty pans or frying pans on switched on cooking zones.
- Do not use steam jets to clean the appliance.
- Do not use rough or abrasive materials or sharp metal scrapers.
- Do not use cleaning products containing chlorine, ammonia or bleach on parts made of steel or that have metallic surface finishes (e.g. anodizing, nickel- or chromium-plating).
- Do not use abrasive or corrosive detergents (e.g. scouring powders, stain removers and metallic sponges) on glass parts.
- Do not wash the removable components such as the hob grids, flame-spreader crowns and burner caps in a dishwasher.
- Never use the oven door to lever the appliance into place when fitting.
- Avoid exerting too much pressure on the door when open.
- Do not use the handle to lift or move this appliance.

### Installation

- **THIS APPLIANCE MUST NOT BE INSTALLED IN A BOAT OR CARAVAN.**
- The appliance must not be installed on a pedestal.
- Position the appliance into the cabinet cut-out with the help of a second person.
- To prevent any possible overheating, the appliance should not be installed behind a decoration door or a panel.
- Have the gas connection performed by authorised staff.



- Installation using a hose must be carried out so that the length of the hose does not exceed 2 metres when fully extended for steel hoses and 1.5 metres for rubber hoses.
- The hoses should not come into contact with moving parts and should not be crushed in any way.
- If required, use a pressure regulator that complies with current regulations.
- After carrying out any operation, check that the tightening torque of gas connections is between 10 Nm and 15 Nm.
- At the end of the installation, check for any leaks with a soapy solution, never with a flame.
- Have the electrical connection performed by authorised technicians.
- The appliance must be connected to ground in compliance with electrical system safety standards.
- Use cables withstanding a temperature of at least 90 °C.
- The tightening torque of the screws of the terminal board leads must be 1.5 - 2 Nm.

## For this appliance

- Ensure that the appliance is switched off before replacing the bulb.
- Do not rest any weight or sit on the open door of the appliance.
- Take care that no objects are stuck in the doors.

## 1.2 Manufacturer liability

The manufacturer declines all liability for damage to persons or property caused by:

- Use of the appliance other than that specified;
- failure to comply with the instructions in the user manual;
- tampering with any part of the appliance;
- use of non-original spare parts.



## Instructions

### 1.3 Appliance purpose

- This appliance is intended for cooking food in the home environment. Every other use is considered inappropriate.
- The appliance is not designed to operate with external timers or with remote-control systems.

### 1.4 Identification plate

The identification plate bears the technical data, serial number and brand name of the appliance. Do not remove the identification plate for any reason.

### 1.5 This user manual

This user manual is an integral part of the appliance and must therefore be kept in its entirety and within the user's reach for the whole working life of the appliance.

Read this user manual carefully before using the appliance.

### 1.6 Disposal



This appliance must be disposed of separately from other waste (Directives 2002/95/EC, 2002/96/EC, 2003/108/EC). The appliance does not contain substances in quantities sufficient to be considered hazardous to health and the environment, in accordance with current European directives.

To dispose of the appliance:

- Cut the power supply cable and remove it along with the plug.



**Power voltage**

**Danger of electrocution**

- Disconnect the mains power supply.
- Unplug the appliance.





- Deliver the appliance to the appropriate recycling centre for electrical and electronic equipment waste, or return it to the retailer when purchasing an equivalent product, on a one for one basis.

Our appliances are packaged in non-polluting and recyclable materials.

- Deliver the packing materials to the appropriate recycling centre.



## Plastic packaging Danger of suffocation

- Do not leave the packaging or any part of it unattended.
- Do not let children play with the plastic bags.

## 1.7 How to read the user manual

This user manual uses the following reading conventions:

	<b>Instructions</b> General information on this user manual, on safety and final disposal.
	<b>Description</b> Description of the appliance and its accessories.
	<b>Use</b> Information on the use of the appliance and its accessories.
	<b>Cleaning and maintenance</b> Information for proper cleaning and maintenance of the appliance.
	<b>Installation</b> Information for the qualified technician: Installation, operation and inspection.



Safety instructions



Information



Advice

1. Use instruction sequence.

- Standalone instruction.



# Description

## 2 Description

### 2.1 General Description

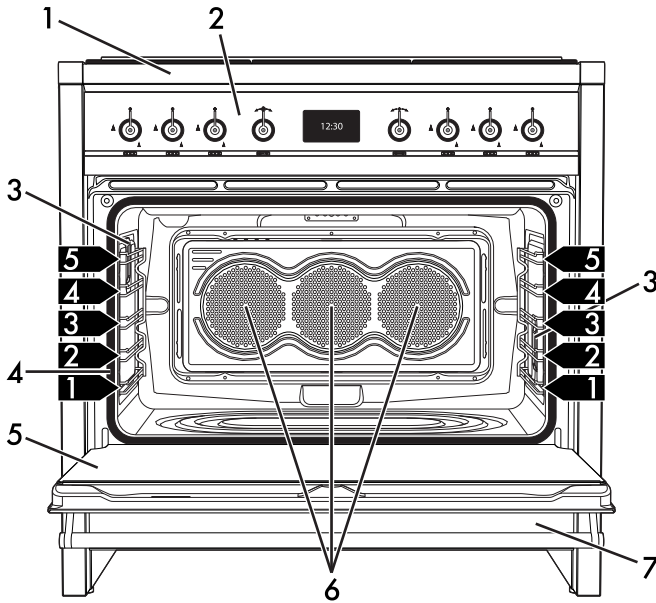

- 1 Cooking hob
- 2 Control panel
- 3 Lamp
- 4 Seal

- 5 Door
- 6 Fan
- 7 Storage compartment
- 1,2,3...** Rack/tray support frames



## 2.2 Control panel

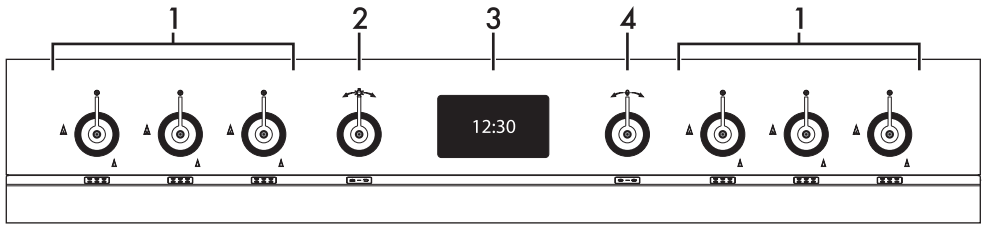



### 1 Hob burner knobs

Used for lighting and adjusting the hob burners.

Press and turn the knobs anti-clockwise to

 in order to light the relative burners.

Turn the knobs to the zone between the maximum  and minimum  setting to adjust the flame.

Return the knobs to the position  to turn off the burners.

### 2 Return knob —

This knob allows you to return to the previous item in the appliance's menu. It also lets you manually turn the oven light on and off.

### 3 Display

Displays the current time, the selected cooking temperature and function and any time set.

### 4 Control knob —

This knob allows you to turn the appliance on and off and select the various available functions.

Turn the knob right or left to change/select the required item.

Press to confirm.



Keep the knob pressed in for at least 5 seconds to immediately complete any cooking operation.



## Description

### 2.3 Cooking hob

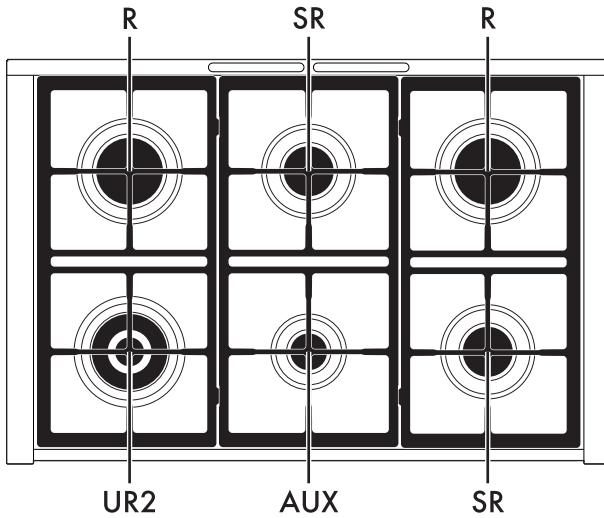

AUX = Auxiliary  
SR = Semi-rapid

R = Rapid  
UR2 = Ultra-rapid

### 2.4 Other parts

#### Shelves

The appliance features shelves to position trays and racks at different heights. The insertion heights are indicated from the bottom upwards (see 2.1 General Description).

#### Cooling fan

The fan cools the oven and comes into operation during cooking.

The fan causes a steady outflow of air that exits from the rear of the appliance and which may continue for a brief period of time even after the appliance has been turned off.

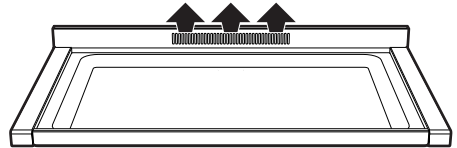





Do not obstruct ventilation openings and heat dispersal slots.



## Interior lighting

The appliance's interior lighting comes on:

- when the door is opened:
- when any function is started, Vapor Clean , ECO Pyrolytic  and Pyrolytic  Functions excluded (depending on the model).
- When the temperature knob is rotated a bit to the right (manual on and off).

 When the door is open, it is not possible to turn off the interior lighting.

## 2.5 Available accessories

### Wok ring

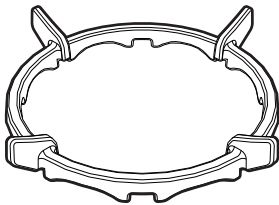

Useful when using a wok.

### Tray rack

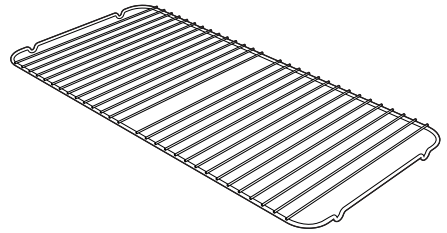

To be placed over the top of the oven tray; for cooking foods which may drip.

### Oven tray

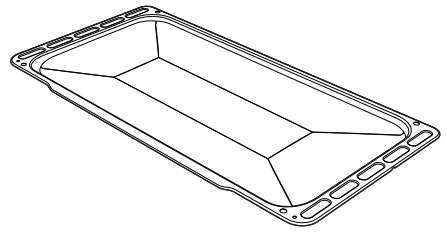

Useful for collecting fat from foods placed on the rack above.

### Deep tray

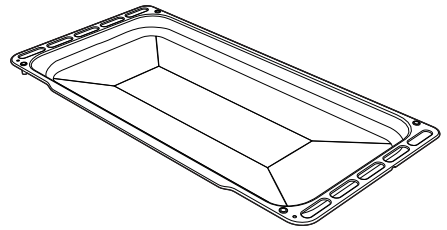

Useful for collecting fat from foods placed on the rack above and for cooking pies, pizzas and baked desserts.



## Description

### Rack

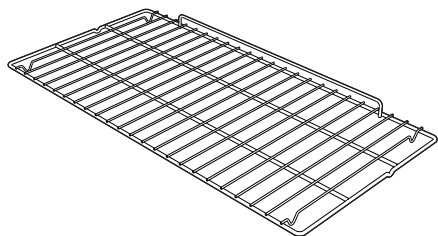

Used for supporting containers with food during cooking.

### Rotisserie (on some models only):

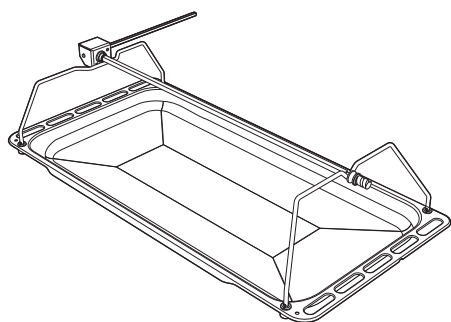

Useful for cooking chicken and all food that require uniform cooking over their entire surface.

### Self-cleaning panels (on some models only)

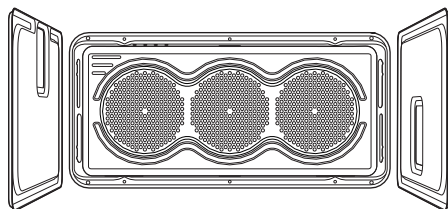

Useful for absorbing small grease residues.



Some models are not provided with all accessories.



The accessories intended to come into contact with food are made of materials that comply with the provisions of current legislation.



Supplied and optional accessories can be requested to Authorised Service Centres. Use only original accessories supplied by the manufacturer.



## 3 Use

### 3.1 Instructions



**High temperature inside the oven during use**

**Danger of burns**

- Keep the oven door closed during cooking.
- Protect your hands by wearing oven gloves when moving food inside the oven.
- Do not touch the heating elements inside the appliance.
- Do not pour water directly onto very hot trays.
- Keep children under the age of 8 away from the appliance when it is in use.
- If you need to move food or at the end of cooking, open the door 5 cm for a few seconds, let the steam come out, then open it fully.



**Improper use**

**Danger of burns**

- Make sure that the flame-spreader crowns are correctly positioned in their seats with their respective burner caps.
- Oils and fats could catch fire if overheated. Be very careful.



**Improper use**

**Risk of damage to surfaces**

- Do not cover the bottom of the oven cavity with aluminium or tin foil sheets.
- If you wish to use greaseproof paper, place it so that it will not interfere with the hot air circulation inside the oven cavity.
- Do not place pans or trays directly on the bottom of the oven cavity.
- Do not use the open door to place pans or trays on the internal glazing pane.
- Do not pour water directly onto very hot trays.
- Cooking vessels or griddle plates should be placed inside the perimeter of the hob.
- All pans must have smooth, flat bottoms.
- If any liquid does boil over or spill, remove the excess from the hob.



**High temperature inside the storage compartment**

**Danger of burns**

- Do not open the storage compartment when the appliance is on and still hot.
- The items inside the storage compartment could be very hot after using the appliance.



## High temperature inside the storage compartment during use Danger of fire or explosion

- Do not spray any spray products near the appliance.
- Do not use or leave flammable materials near the appliance or the storage compartment.
- Do not use plastic cookware or containers for cooking.
- Do not put sealed tins or containers in the oven.
- Never leave the appliance unattended during cooking operations where fats or oils could be released.
- Remove all trays and racks which are not required during cooking.

## 3.2 Precautions

### A gas leak can cause an explosion.

If you smell gas or there are faults in the gas system:

- Immediately turn off the gas supply or close the valve on the gas cylinder.
- Extinguish all open flames and cigarettes.
- Do not turn on power switches or appliances and do not remove plugs from power sockets. Do not use phones or mobile phones inside the building.
- Open the window in order to ventilate the room.
- Call customer assistance services or your gas supplier.

## Malfunctions

Any of the following indicate a malfunction and you should contact a service centre.

- Yellowing of the burner plate.
- Damage to kitchen utensils.
- The burners do not ignite properly.
- It is difficult to keep the burners lit.
- The burners go out when the appliance is in use.
- It is difficult to turn the gas valves.

If the appliance does not work properly, contact your local Authorised Service Centre.

## 3.3 First use

1. Remove any protective film from the outside or inside of the appliance, including accessories.
2. Remove any labels (apart from the technical data plate) from the accessories and from the oven cavity.
3. Remove and wash all the appliance accessories (see 4 Cleaning and maintenance).
4. Heat the empty appliance at the maximum temperature to burn off any residues left by the manufacturing process.





### 3.4 Using the accessories

#### Ring reducers

The ring reducers have to be placed on the hob grids. Make sure they are placed properly.

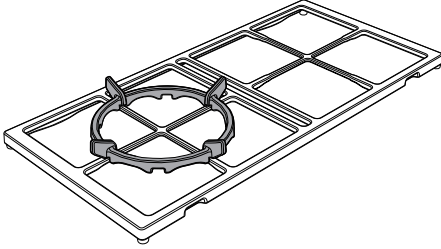

#### Tray rack

The tray rack has to be inserted into the tray. In this way fat can be collected separately from the food which is being cooked.

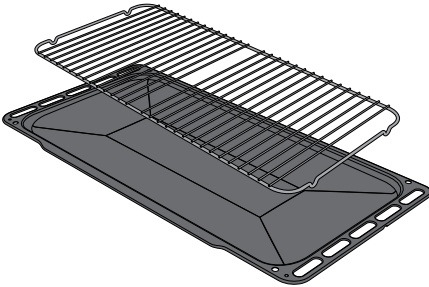

#### Racks and trays

Racks and trays have to be inserted into the side guides until they come to a complete stop.

The mechanical safety locks that prevent the rack from being removed accidentally must face downwards towards the back of the oven cavity.

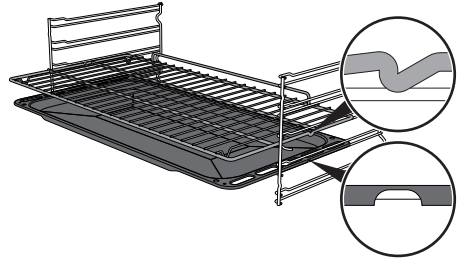

Gently insert racks and trays into the oven until they come to a stop.



Clean the trays before using them for the first time to remove any residues left by the manufacturing process.



## Use

### Rotisserie (on some models only)

1. Insert the four supplied bushings in the four corner holes of the deep tray and screw them onto the ring nuts with a suitable tool (such as a screwdriver).

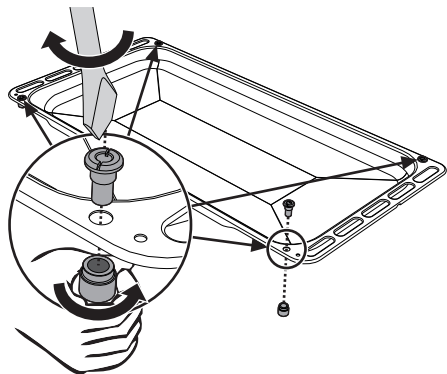

2. Position the rotisserie supports in the bushings as shown in the figure below.

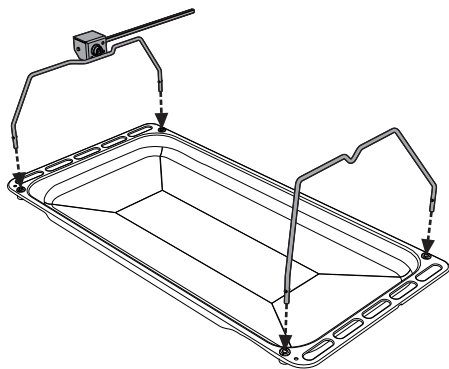

3. Prepare the rotisserie rod with the food using the rotisserie rod provided. The clip forks can be tightened using the fastening screws.

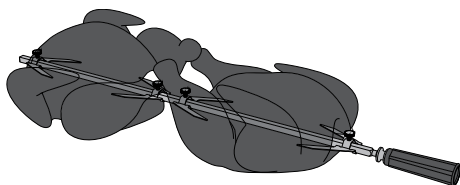
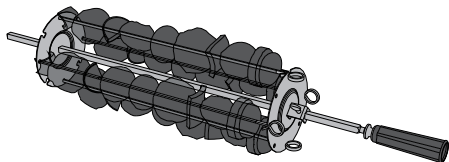

4. Once you have prepared the rotisserie rod, place it on the supports. Insert the tip of the rod in the housing of the mechanism on the left-hand support until it stops.

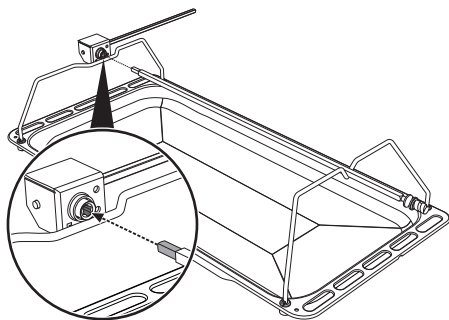



5. Place the tray on the first runner (see "General Description").
6. Insert the tip of the rod in the rotisserie motor housing on the left of the rear wall of the oven cavity.

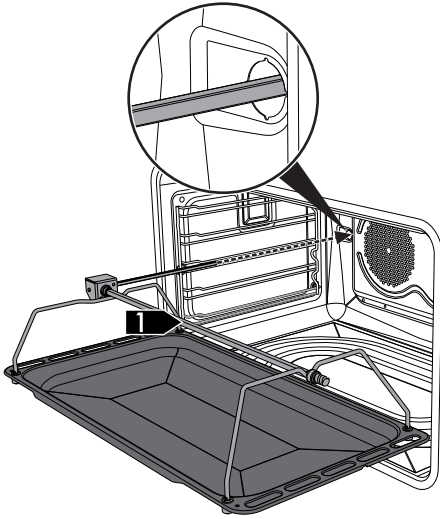

These operations must be performed with the oven off and cold.

7. To activate the rotisserie, turn the function knob to the  position and set the cooking temperature using the temperature knob.



Pour a little water into the tray to prevent smoke from forming.

8. When cooking is complete, remove the tray with the rotisserie.
9. Screw on the handle provided so that you can handle the rotisserie rod more easily.

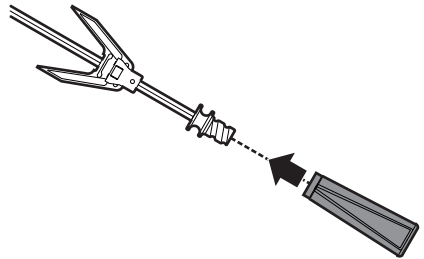



## 3.5 Using the hob

All the appliance's control and monitoring devices are located together on the front panel. The burner controlled by each knob is shown next to the knob. The appliance is equipped with an electronic ignition device. Simply press the knob and turn it anti-clockwise to the maximum flame symbol, until the burner ignites. If the burner does not light in the first 15 seconds, turn the knob to

 and wait 60 seconds before trying again. After lighting, keep the knob pressed in for a few seconds to allow the thermocouple to heat up.

The burner may go out when the knob is released: in this case, the thermocouple has not heated up sufficiently. Wait a few moments and repeat the operation. Keep the knob pressed in longer.



In case of an accidental switching off, a safety device will be tripped, cutting off the gas supply, even if the gas cock is open. Return the knob to  and wait at least 60 seconds before lighting it again.

### Correct positioning of the flame-spreader crowns and burner caps

Before lighting the hob burners, make sure that the flame-spreader crowns are correctly positioned in their seats with their respective burner caps. Make sure that the holes **1** of the flame-spreader crowns are aligned with the thermocouples **2** and igniters **3**.

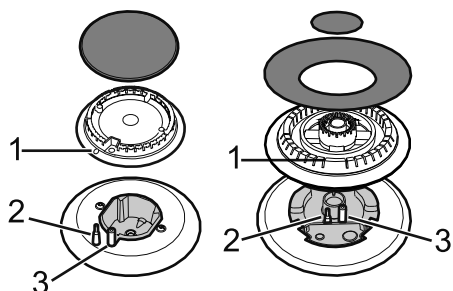

### Practical tips for using the hob

For better burner efficiency and to minimise gas consumption, use pans with lids and of suitable size for the burner, so that the flames do not reach up the sides of the pan. Once the contents come to the boil, turn down the flame far enough to ensure that the liquid does not boil over.



Cookware diameters:

- AUX: 12 - 14 cm.
- SR: 16 - 24 cm.
- R: 18 - 26 cm.
- UR2: 18 - 28 cm.



### Correct position of the hob racks

Before lighting the hob burners, make sure that the racks are in place on the same hob.

Remember that:

- The appliance has two side racks (**A**) and a centre one (**B**).

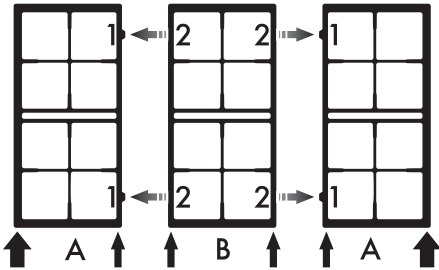

- The side racks (**A**) have a thicker edge that should be facing the side of the appliance.
- The reference projections (**1**) should be facing the centre of the hob.
- The side racks (**A**) must be placed on the hob as first elements.
- The centre rack (**B**) edges have the same thickness.

- Position the centre rack (**B**) so that the notches (**2**) are aligned with the reference projections (**1**) of the side racks (**A**).

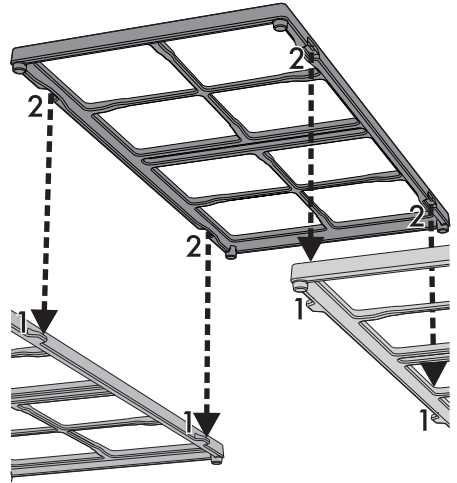

### 3.6 Using the storage compartment

There is a storage compartment located at the bottom of the cooker; this can be used to store pans or metal objects required for its use.

- To open the storage compartment, pull the handle towards you.

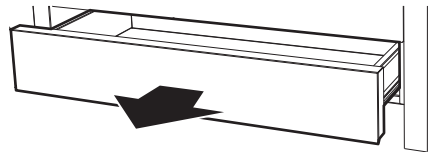



## 3.7 Using the oven

### First use

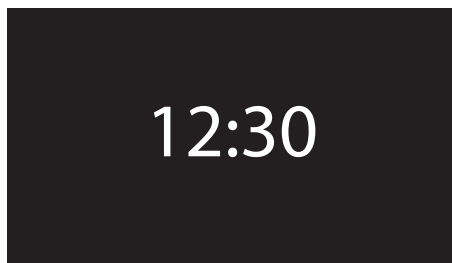

On the first use, or after a power failure, **00:00** will be flashing on the appliance's display. In order to be able to start any cooking operation, the current time must be set (if the oven is being turned on for the first time, it is also recommended you set the required language).

Press the control knob to enter the settings menu, see "3.12 Settings".



The appliance language is set to "English" by default.



When first connecting or after the power has been cut for a time it will be necessary to wait a few seconds before you can interact with the appliance.

### Reactivating the display

If the Eco-Light mode is active (see "Eco-Light" in the "Settings" chapter), the display will switch off 2 minutes after the appliance was last used.

To reactivate the display when it is off:

- press or turn one of the two knobs.

The appliance will emit a series of sounds and the display will switch on after a few seconds. The display shows the current time screen when it is switched on again.



The lamp inside the oven cavity switches on if you turn the return knob to the right or left to reactivate the display.



The main menu will appear on the display if you reactivate the display by pressing the control knob.

menu

cooking functions

special functions

preset recipes

personal recipes

settings



## Memory

Press the return knob from the clock screen to display the last preset recipes or personal recipes used.

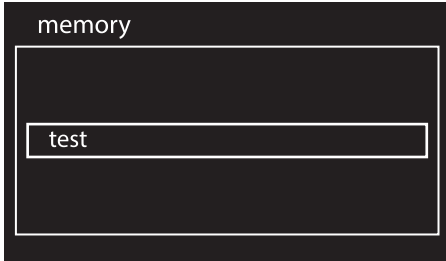

3. Select **YES** if you wish to delete the memory.

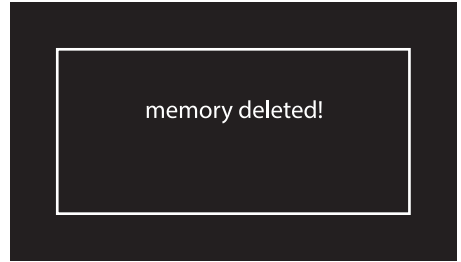

## Deleting the memory

If you wish to delete the memory:

1. Press the return knob from the clock screen to display the last preset recipes or personal recipes used.
2. Press and hold down the control knob for a few seconds.



## Cooking functions

1. On the clock screen, press the control knob to access the main menu.
2. Turn the control knob to the right or left to select **cooking functions** from the main menu.
3. Press the control knob to confirm.

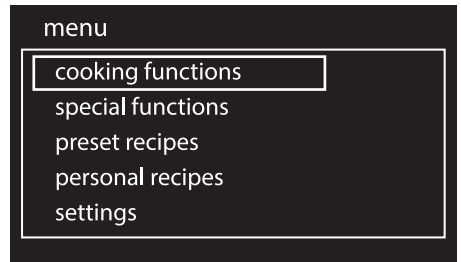

4. Turn the control knob to select the required function.



# Use

5. Press the knob to confirm the selection.

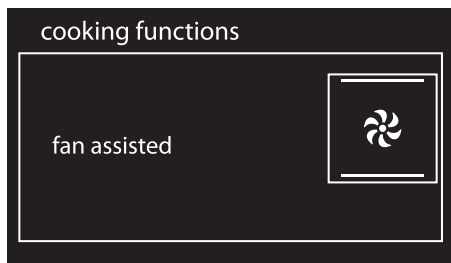

The appliance will begin preheating. The display will show the selected function, the pre-set temperature, the current time and the progress bar of the temperature reached.

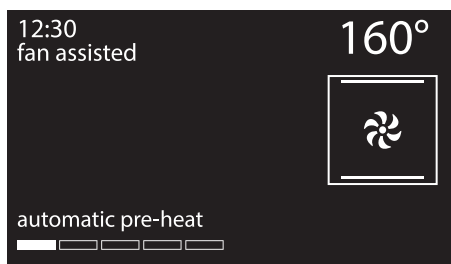

When the preheating stage is over a buzzer will sound to indicate that the food can be placed inside the oven.



## Interrupting a function

To interrupt a cooking function:

1. Press the return knob.
2. Select the required option.
3. Press the return knob to confirm.

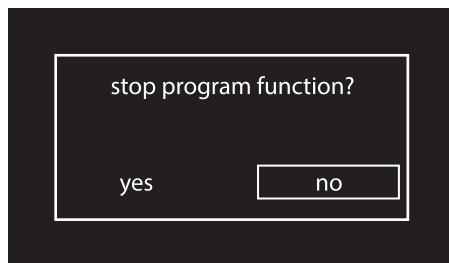

Turn the control knob to change the preset temperature at any time. Press to confirm or wait 5 seconds.



It is not recommended to place food in the oven during the preheating stage.



Keep the control knob pressed in for at least 5 seconds to interrupt cooking immediately at any time and return to the main menu.





## List of cooking functions

**ECO**

### Eco

This function is particularly suitable for cooking on a single shelf with low energy consumption.

Ideal for cooking meat, fish and vegetables. It is not recommended for leavened foods.

To obtain maximum energy savings and reduce cooking times, it is recommended to place food in the oven without preheating.



When using the ECO function, avoid opening the door during cooking.

**i**

Cooking (and preheating) times are longer with the ECO function.

### Conventional

As the heat comes from above and below at the same time, this system is particularly suitable for certain types of food. Traditional cooking, also known as static cooking, is suitable for cooking just one dish at a time. Perfect for all types of roasts, bread and cakes, and in any case, particularly suitable for fatty meats such as goose and duck.

### Grill

The heat coming from the grill element gives perfect grilling results above all for thin and medium thickness meat and, in combination with the rotisserie (where fitted), gives the food an even browning at the end of cooking. Perfect for sausages, spare ribs and bacon. This function enables large quantities of food, particularly meat, to be grilled evenly.

### Lower element

The heat coming just from the bottom allows you to complete the cooking of foods that require a higher bottom temperature, without affecting their browning. Perfect for cakes, pies, tarts and pizzas.



### Fan assisted

The operation of the fan, combined with traditional cooking, ensures consistent cooking even with complex recipes. Perfect for biscuits and cakes, even when simultaneously cooked on several levels. (For multiple-level cooking, we recommend using the 1<sup>st</sup> and 4<sup>th</sup> shelves).



## Fan with grill

The air produced by the fan softens the strong heatwave generated by the grill, grilling perfectly even very thick foods. Perfect for large cuts of meat (e.g. shin of pork).



## Fan + lower element

The combination of the fan with just the lower heating element allows cooking to be completed more rapidly. This system is recommended for sterilising or for finishing off the cooking of foods which are already well-cooked on the surface, but not inside, which therefore need a little more heat. Perfect for any type of food.



## Circulaire

The combination of the fan and the circulaire heating element (incorporated in the rear of the oven) allows you to cook different foods on several shelves, as long as they need the same temperatures and the same type of cooking. Hot air circulation ensures instant and even distribution of heat. It will be possible, for instance, to cook fish, vegetables and biscuits simultaneously (on different levels) without odours and flavours mingling.



## Supercook

The combination of fan assisted cooking and traditional cooking allows different foods to be cooked on several levels extremely quickly and efficiently, without odours and flavours mingling. Perfect for large volumes that call for intense cooking. (For multiple-level cooking, we recommend using the 1<sup>st</sup> and 4<sup>th</sup> shelves).



## Circulaire + fan with grill

The combination of fan assisted cooking and traditional cooking allows you to cook different foods on several levels extremely quickly and efficiently, without odours and flavours mingling. Perfect for large volumes that call for intense cooking.





## Minute minder during a function

**i** This function only activates the buzzer, without stopping cooking.

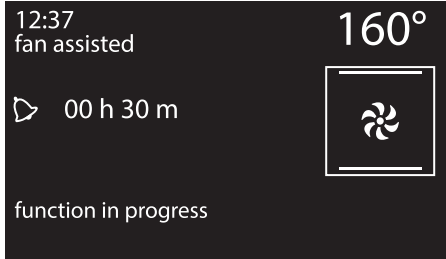
1. Press the control knob during a cooking function.
2. Turn the control knob right or left to set the duration (from 1 minute to 4 hours). After a few seconds, the symbol  stops flashing and the countdown starts.



3. Wait for the buzzer to indicate that the time has finished. The symbol  flashes.

 Turn the knob to the left or right to select another timer, or press the control knob to stop the buzzer.

## Timed cooking

**i** Timed cooking is the function which allows a cooking operation to be started and then ended after a specific length of time set by the user.

**i** Activation of timed cooking cancels any minute minder timer which may previously have been set.

1. After selecting a cooking function and temperature, press the control knob twice.
2. Turn the knob right or left to set the minutes of cooking from 00:01 to 13:00. Keep the knob turned to produce a faster increase or decrease.





## Use

3. A few seconds after the required duration is set, the symbol  stops flashing and timed cooking starts.

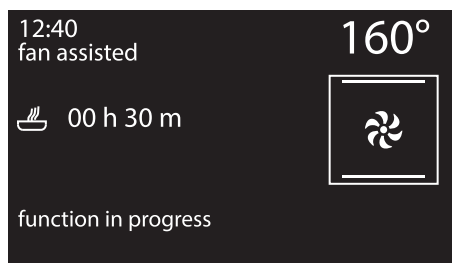

4. At the end of the cooking cycle, "function ended" appears on the display and a buzzer will sound that can be deactivated by pressing the control knob.

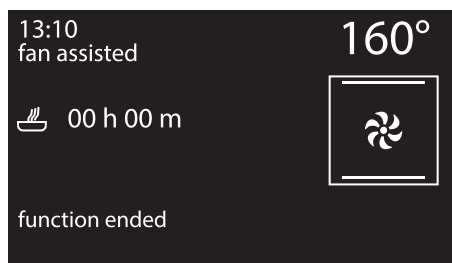

Turn the control knob to add some minutes of cooking time.





To extend the cooking time manually, press the control knob again. The appliance will resume its normal operation with the previously selected cooking settings.



To turn off the appliance see "Interrupting a function".

### Modifying the data set during timed cooking

During operation, it is possible to modify timed cooking duration:

1. When the symbol  is steady and the appliance is in the cooking phase, press the control knob. The symbol  will start flashing.
2. Turn the control knob right or left to alter the preset cooking time.





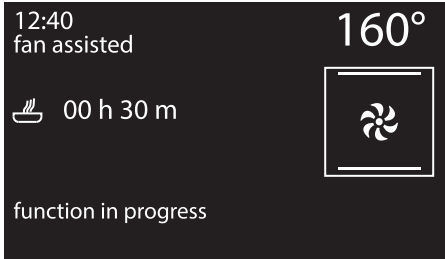

## Programmed cooking

**i** Programmed cooking is the function which allows a cooking operation to be stopped at an established time depending on the time set by the user, after which the oven will switch off automatically.

1. After selecting a function and a cooking temperature, press the control knob to set the cooking time.



2. Press the control knob before the symbol  stops flashing to set the cooking end time.
3. The symbol  flashes. Turn the knob right or left to set the cooking end time.

4. After a few seconds the symbols  and  stop flashing. The appliance waits for the delay start time.



5. Based on the values set, the appliance will start a preheating stage of approximately 10 minutes...

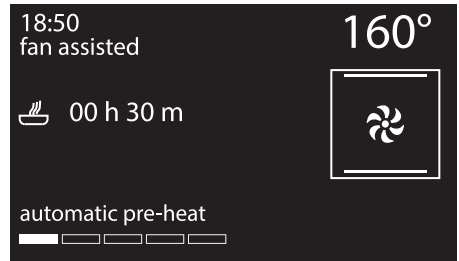

6. ... and it will then proceed with the selected function.





- At the end of the cooking cycle, "function ended" appears on the display and a buzzer will sound that can be deactivated by pressing the control knob.

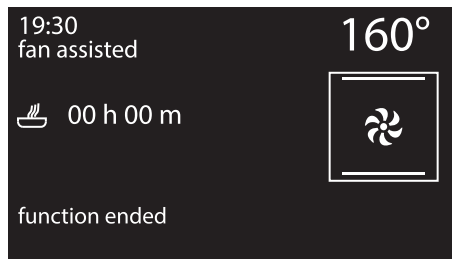

To extend the cooking time manually, press the control knob again. The appliance will resume its normal operation with the previously selected cooking settings.









For safety reasons, it is not possible to set the end of cooking time by itself without setting the cooking duration.

## Modifying the data set during programmed cooking



After modifying the cooking duration, the end of cooking time must be re-set.

During operation, it is possible to modify programmed cooking duration:

- When the symbols  and  are lit steadily and the appliance is waiting for cooking to start, press the control knob. The symbol  will start flashing.
- Turn the control knob to alter the previously set cooking time.
- Press the control knob again. The symbol  switches off and  starts flashing. The display shows the cooking end time.
- Turn the control knob to delay the cooking end time.
- After a few seconds the symbols  and  stop flashing and programmed cooking restarts with the new settings.



If the cooking duration is modified, the cooking end time is deleted.



## 3.8 Cooking advice

### General advice

- Use a fan assisted function to achieve consistent cooking at several levels.
- It is not possible to shorten cooking times by increasing the temperature (the food could be overcooked on the outside and undercooked on the inside).
- For the same total weight, cooking time will be greater for cooking a whole piece than when it is cut into smaller pieces.

### Advice for cooking meat

- Cooking times vary according to the thickness and quality of the food and to consumer taste.
- Use a meat thermometer when roasting meat, or simply press on the roast with a spoon. If it is hard, it is ready; If not, it needs another few minutes cooking.

### Advice for cooking with the Grill

- Meat can be grilled even when it is put into the cold oven or into the preheated oven if you wish to change the effect of the cooking.
- When using the Fan with grill function, we recommend that you preheat the oven before grilling.
- We recommend placing the food at the centre of the rack.

### Advice for cooking desserts/pastries and biscuits

- Use dark metal moulds: They help to absorb the heat better.
- The temperature and the cooking time depend on the quality and consistency of the dough.
- When cooking on multiple levels, food should ideally be positioned on the second and fourth shelves; increase cooking time by a few minutes and only used fan functions.
- To check whether the dessert is cooked right through: at the end of the cooking time, put a toothpick into the highest point of the dessert. If the dough does not stick to the toothpick, the dessert is cooked.
- If the dessert collapses when it comes out of the oven, on the next occasion reduce the set temperature by about 10 °C, selecting a longer cooking time if necessary.
- The cooking time for meringues and choux pastry will vary depending on the size.

### Advice for defrosting and proving

- Place frozen foods without their packaging in a lidless container on the first shelf of the oven.
- Avoid overlapping the food.



- To defrost meat, use the rack placed on the second level and a tray on the first level. In this way, the liquid from the defrosting food drains away from the food.
- Bread and fruit, if divided into pieces, will take the same amount of time to defrost, regardless of the total weight and quantity.
- The most delicate parts can be covered with aluminium foil.
- For successful proving, a container of water should be placed in the bottom of the oven.

## To save energy

- Stop cooking a few minutes before the time normally used. Cooking will continue for the remaining minutes with the heat which has accumulated inside the oven.
- Reduce any opening of the door to a minimum to avoid heat dispersal.
- Keep the inside of the appliance clean at all times.
- (Where fitted) When it is not being used, remove the pizza stone from the base of the oven.

## 3.9 Special functions

**i** The special functions menu contains some functions like the timer with the oven off, defrosting or cleaning functions.

1. On the clock screen, press the control knob to access the main menu.
2. Turn the control knob to the right or left to select **special functions** from the main menu.
3. Press the control knob to confirm.

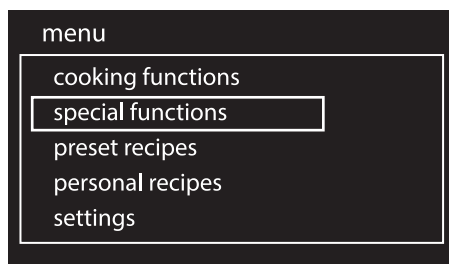

**i** Certain functions are not available on all models.





## List of special functions



### Minute minder

This function sounds a buzzer when the time set has elapsed.



### Defrost by weight

This function defrosts foods on the basis of the type and weight of the frozen product.



### Defrost by time

This function allows you to defrost food on the basis of a selectable time.



### Proving

The proving function, using the heat coming from the top, makes it possible to prove all types of dough, guaranteeing perfect results quickly.



### Grill + Rotisserie

The rotisserie works in combination with the grill element, allowing food to be perfectly browned.



### Food warming

To heat food or keep it hot.



### Sabbath mode

This function allows food to be cooked in accordance with the provisions of the Jewish religion day of rest.



### Vapor clean (on some models only)

This function facilitates cleaning using the steam produced by a small quantity of water poured onto the appropriate drawing placed on the bottom.



### ECO pyrolytic (on some models only)

When this function is set, the appliance executes a pyrolytic cycle at 500 °C for a pre-set time. For use in the case of ovens which are not too dirty.



### Pyrolytic (on some models only)

Setting this function, the appliance reaches temperatures up to 500 °C, destroying all the grease which forms on the internal walls.



The more complex special functions will be described below. For functions such as **Vapor Clean**, **ECO Pyrolytic** and **Pyrolytic** functions, see "4 Cleaning and maintenance".



## Use

### Minute minder

1. Turn the control knob to the right or left to select **timer** from the “special functions” menu.
2. Press the control knob to confirm.

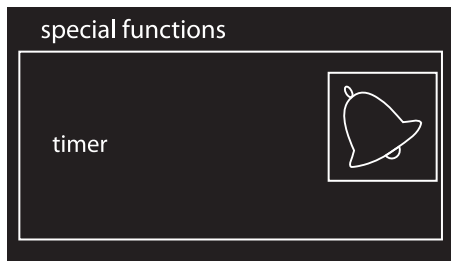

3. Turn the control knob right or left to set the duration (from 1 minute to 4 hours). After a few seconds, the symbol  stops flashing and the countdown starts.



4. If you leave the timer setting screen, the symbol  will be displayed at the top left, indicating that a minute minder is active.

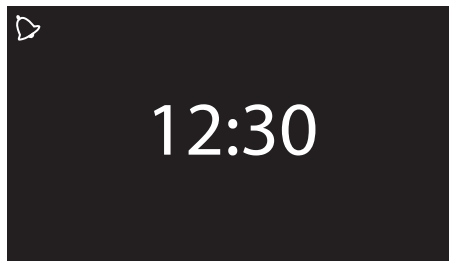

You must return the counter to zero to remove the special timer.



If a function is activated after setting a timer time, this time will be automatically used as a timer for the function, except for some special functions, automatic programs and personal recipes.



This function only activates the buzzer, without stopping cooking.



## Defrost by weight

1. Place the food inside the appliance.
2. Turn the control knob to the right or left to select **defrost by weight** from the "special functions" menu.
3. Press the control knob to confirm.

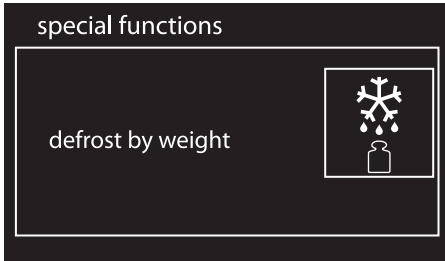

4. Turn the control knob to select the type of food to defrost.

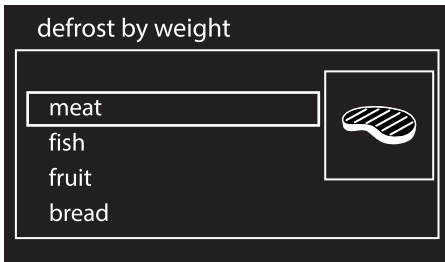

5. Turn the control knob to select the weight (in kilograms) of the food to defrost.



6. Press the control knob to confirm the set parameters.

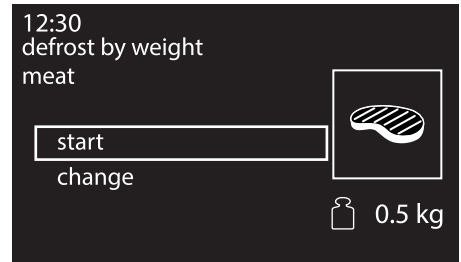

7. Press the control knob again to start defrosting, or select change to further modify the set parameters.





# Use

- At the end of the function, "function ended" appears on the display and a buzzer will sound that can be deactivated by pressing the control knob.

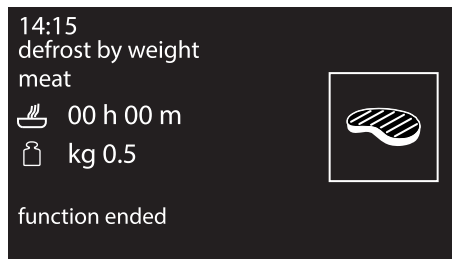

## Defrost by time

- Place the food inside the appliance.
- Turn the control knob to the right or left to select **defrost by time** from the "special functions" menu.
- Press the control knob to confirm.

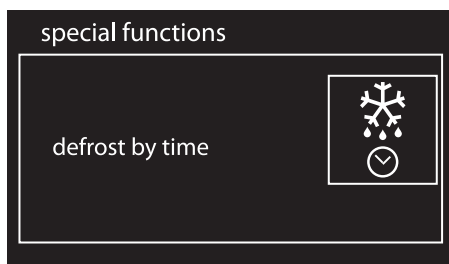

Pre-set parameters:

Type	Weight (g)	Time (default)
Meat	0.1 to 1.1 (default 0.5)	02h 00m
Fish	0.1 to 0.7 (default 0.3)	00h 55m
Fruit	0.1 to 0.5 (default 0.3)	00h 35m
Bread	0.1 to 0.5 (default 0.3)	00h 25m

\* Defrosting times may vary on the basis of the shape and size of the food to be defrosted.

- Turn the control knob to adjust the value (from 1 minute to 13 hours).

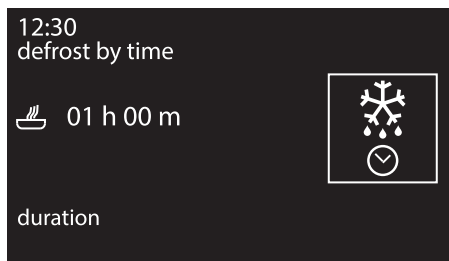



- Press the control knob to confirm the set parameters.

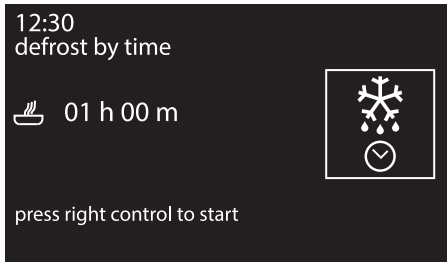

- Press it again to start defrosting.
- While the function is in progress, it is possible to further modify the defrosting duration. Turn the control knob to the right or left to make the required changes.
- Press the control knob to confirm the new defrosting duration set. In any event, the defrosting will automatically resume 5 seconds from the last modification.
- At the end of the function, "function ended" appears on the display and a buzzer will sound that can be deactivated by pressing the control knob.



## Proving



For successful proving, a container of water should be placed in the bottom of the oven.

- Position the dough to prove on the second level.
- Turn the control knob to the right or left to select **proving** from the "special functions" menu.
- Press the control knob to confirm.

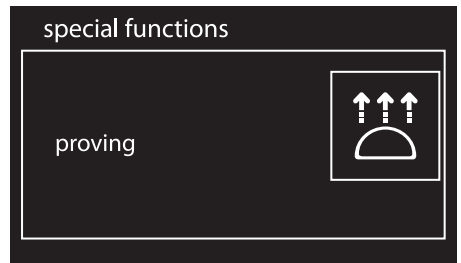

- Press the control knob to start the function.

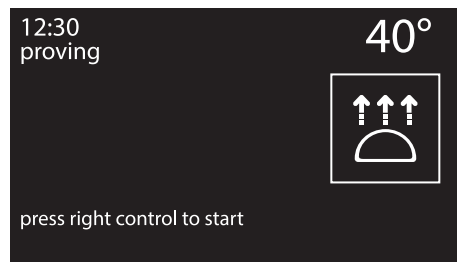



## Use

5. The appliance will begin preheating...

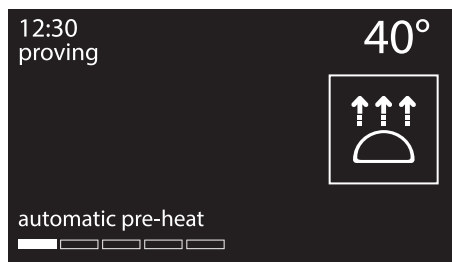

6. ... and it will then proceed with the selected function.

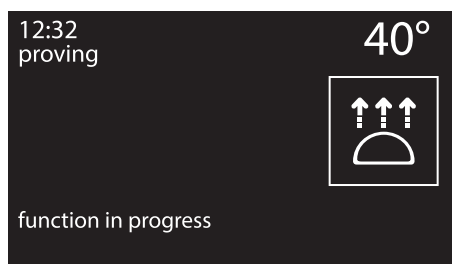

While the function is in progress, it is possible to set a timer for a maximum of 4 hours (see "Minute minder during a function"), a proving duration (see "Timed cooking") or delayed proving (see "Programmed cooking").

7. Press the control knob to make the desired changes.

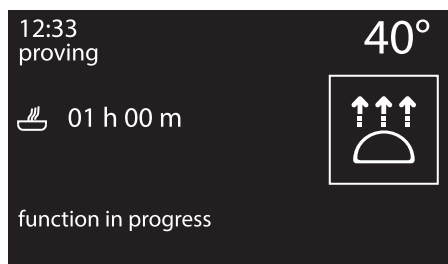

**i** Unless otherwise set, the proving will have a maximum duration of 13 hours.

**i** The light inside the oven will remain off during the proving function.

8. At the end of the function, "function ended" appears on the display and a buzzer will sound that can be deactivated by pressing the control knob.

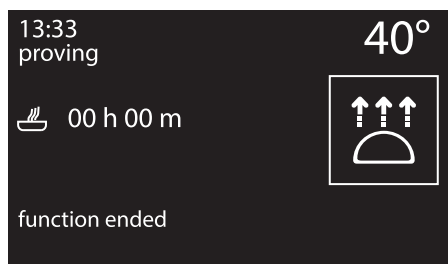

**i** When using the proving function the temperature cannot be altered.



## Food warming

1. Position the tray on the first shelf and place the plates to be warmed on it.

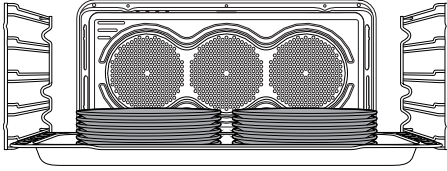

Do not stack plates too high. Stack max. 5/6 plates, for a maximum of two rows.

2. Turn the control knob to the right or left to select **food warming** from the "special functions" menu.
3. Press the control knob to confirm.

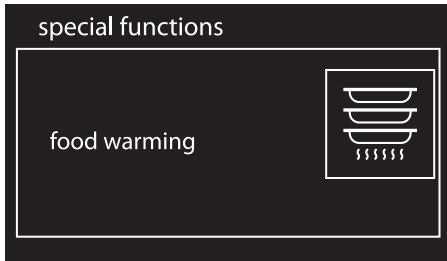

4. Press the control knob to activate the function, or turn it to adjust the preset temperature (from 40° to 80°).



5. The appliance will begin preheating...



6. ... and it will then proceed with the selected function.





## Use

While the function is in progress, it is possible to set a timer for a maximum of 4 hours (see "Minute minder during a function"), a warming duration (see "Timed cooking") or a delayed warming (see "Programmed cooking").

7. Press the control knob to make the desired changes.



8. At the end of the function, "function ended" appears on the display and a buzzer will sound that can be deactivated by pressing the control knob.

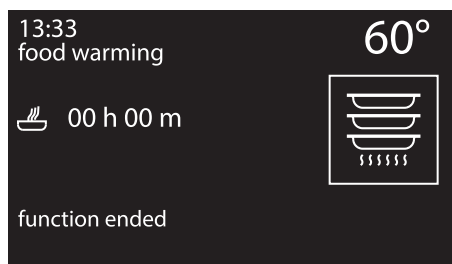

When using the food warming function the temperature cannot be altered.

## Sabbath mode



This function results in the appliance operating in a particular way:

- Cooking can proceed indefinitely, it is not possible to set any cooking duration.
- No preheating will be performed.
- The cooking temperature which can be selected varies between 60-100 °C.
- The oven light remains turned off, any action such as opening the door or manually turning on the oven via the control knob does not turn the lamp on.
- The internal fan remains turned off.
- Knob illumination and audible prompts remain disabled.



After activating the Sabbath mode the settings cannot be altered.

Using the knobs will have no effect; only the control knob remains active to allow you to return to the main menu.

1. Turn the control knob to the right or left to select **Sabbath** from the "special functions" menu.





2. Press the control knob to confirm.

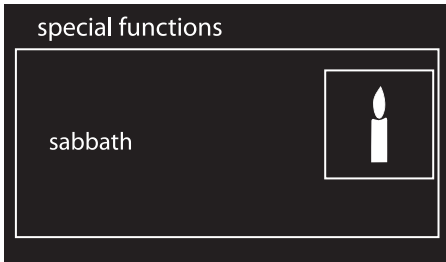

3. Turn the control knob to the right or left to change the heating temperature.

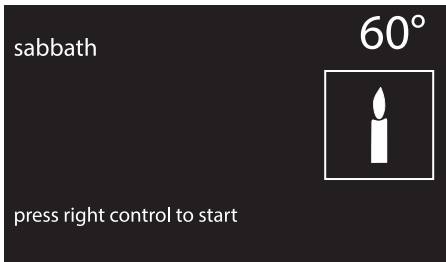

4. Press the control knob to start the Sabbath function.

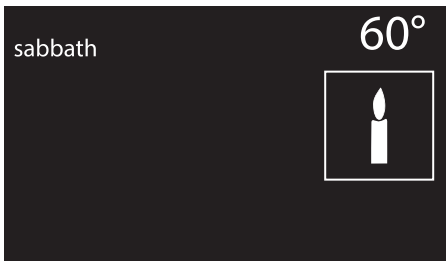

5. When finished, keep the control knob pressed in for at least 5 seconds to return to the main menu.

### 3.10 Preset recipes



This mode allows you to select a previously stored program for cooking food. The appliance will automatically calculate the optimum cooking parameters according to the weight selected.

1. On the clock screen, press the control knob to access the main menu.
2. Turn the control knob to the right or left to select **preset recipes** from the main menu.
3. Press the control knob to confirm.

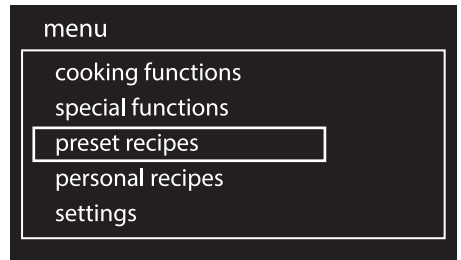

#### Starting a preset recipe

1. Turn the control knob to the right or left to select the required type of dish from the "preset recipes" menu.



## Use

2. Press the control knob to confirm.



3. Select the sub-category of dish to cook and press the control knob to confirm.



4. Select the type of cooking (where possible, depending on the dish chosen) and press the control knob to confirm.

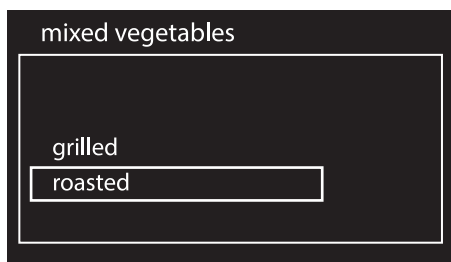

5. Turn the control knob to select the weight of the dish.

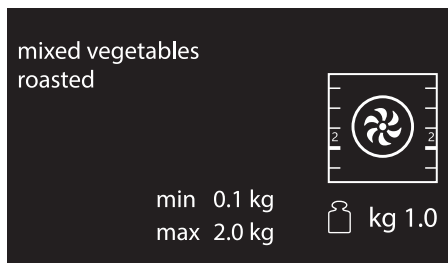

- Now you can start the selected preset recipe, permanently modify the settings or perform delay cooking.

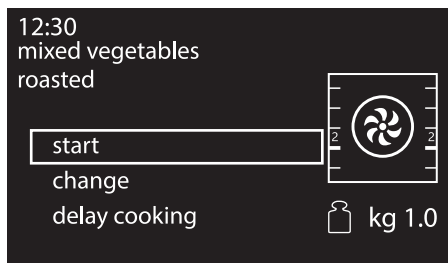

6. If you choose the **start** option, cooking will start with the preset recipe's predefined settings and the display will show all the parameters set.

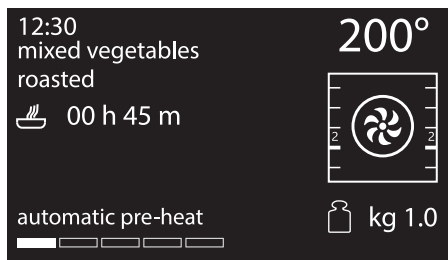



The time shown does not include preheating time.



Some predefined cooking parameters can be changed at any time, even after cooking has started.

- A specific message will indicate when you should put the dish in the oven and start cooking.

12:40  
mixed vegetables  
roasted

00 h 45 m

200°

kg 1.0

put the food in the oven  
and press the right control

- Press the control knob to start cooking.

12:41  
mixed vegetables  
roasted

00 h 44 m

200°

kg 1.0

cooking in progress

## End of a preset recipe

- When the preset recipe has finished, the appliance will warn the user with acoustic signals and the symbol flashing.

13:25  
mixed vegetables  
roasted

00 h 00 m

200°

kg 1.0

cooking completed

- To perform a new cooking operation using the same parameters that are currently set, press the control knob (press twice if the acoustic signal is active). The appliance will begin cooking again automatically if it is still at temperature, otherwise it will start preheating.



Cooking in sequence is useful for cooking multiple dishes of the same type. For example, cooking several pizzas in quick succession.



It is not recommended to place food in the oven during the preheating stage. Wait for the corresponding message.

- Press the return knob to exit and end the preset recipe.



## Use

### Permanently modifying a preset recipe

1. In the selected preset recipe, turn the control knob to the right or left to select **change** from the menu of the selected dish.
2. Press the control knob to confirm.

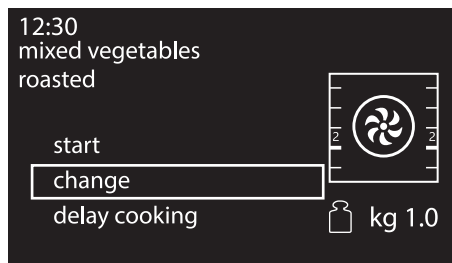

3. Turn the control knob to the right or left to select the **function** to associate with the preset recipe.



4. Press the control knob to confirm.

5. Turn the control knob to the right or left to select the **weight** of the dish to associate with the preset recipe.



6. Press the control knob to confirm.
7. Turn the control knob to the right or left to select the cooking **duration** to associate with the preset recipe.



8. Press the control knob to confirm.



9. Turn the control knob to the right or left to select the cooking **temperature** to associate with the preset recipe.

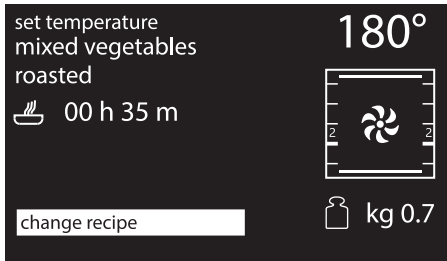

10. Press the control knob to confirm.

11. Turn the control knob to the right or left to select the **shelf** to associate with the preset recipe.



12. Press the control knob to confirm.

13. Pressing the control knob again will return to point 2 of the change sequence. Press the return knob to save the preset recipe. The appliance will ask to confirm the changes which have just been made.

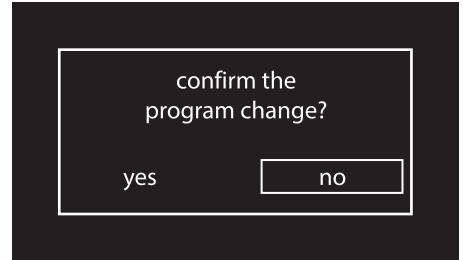

- i** If the modifications are not confirmed, the preset recipe will remain unchanged.

14. If the change is confirmed the display will show confirmation of this.

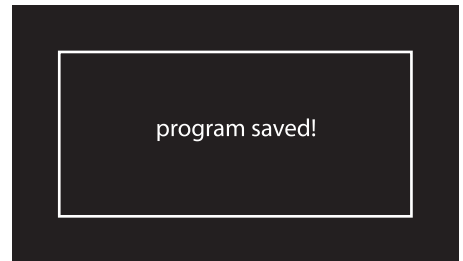

















## Use

### Table of preset recipes

#### MEAT

Subcategory	Cooking	Weight (Kg)	Level	Function	Temp. (°C)	Time (minutes)
Roast beef	Rare	1.3	2		200	49
	Medium	1.3	2		200	56
	Well done	1.4	2		200	70
Roast pork	-	0.8	2		190	88
Lamb	Medium	2	2		190	105
	Well done	2.1	2		190	130
Veal	-	1	2		190	80
Pork spare ribs	-	1	4		250	10 + 6 <sup>(1)</sup>
Pork chops	-	1.3	4		280	14 + 4 <sup>(1)</sup>
Pork sausages	-	1	4		280	8 + 4 <sup>(1)</sup>
Bacon	-	0.4	4		250	4 + 2 <sup>(1)</sup>
Turkey	roasted	2.3	2		190	115
Chicken	roasted	1	2		200	80
Rabbit	roasted	0.9	2		190	75

<sup>(1)</sup> When grilling, it is recommended to cook foods on both sides, making reference to the times given in the table. The greater time always refers to the first side to be cooked, starting with raw foodstuffs.



## FISH

Subcategory	Cooking	Weight (Kg)	Level	Function	Temp. (°C)	Time (minutes)
Fresh fish	-	0.5	2		160	35
Frozen fish	-	0.6	2		160	50
Firm fish	-	1	2		160	50
Delicate fish	-	0.5	2		160	57
Snapper	-	1.2	2		180	65
Flounder	-	1	2		160	40

## VEGETABLES

Subcategory	Cooking	Weight (Kg)	Level	Function	Temp. (°C)	Time (minutes)
Mixed vegetables	grilled	0.5	4		250	15 + 8 <sup>(1)</sup>
	roasted	1	2		200	33
Potatoes	roasted	1	2		200	30
	frozen fried	0.5	2		220	18

<sup>(1)</sup> When grilling, it is recommended to cook foods on both sides, making reference to the times given in the table. The greater time always refers to the first side to be cooked, starting with raw foodstuffs.



## Use

### DESSERTS/PASTRIES

Subcategory	Cooking	Weight (Kg)	Level	Function	Temp. (°C)	Time (minutes)
Ring cake	-	1.5	2		160	50
Biscuits	-	0.5	2		160	23
Muffins	-	0.5	2		160	21
Profiteroles	-	0.5	2		180	70
Meringues	-	0.4	2		130	93
Sponge cake	-	1	2		150	60
Strudel	-	0.8	2		170	45
Tarts	-	1	2		170	43
Brioche bread	-	0.9	2		180	39
Croissants	-	0.5	2		160	35

### BREAD

Subcategory	Cooking	Weight (Kg)	Level	Function	Temp. (°C)	Time (minutes)
Proven bread	-	0.8	2		200	27
Focaccia	-	1	2		180	20









## PIZZA

Subcategory	Cooking	Weight (Kg)	Level	Function	Temp. (°C)	Time (minutes)
Pan pizza	-	0.9	2		280	12
Stone baked pizza	Fresh	0.7	1 <sup>(2)</sup>		280	7
	frozen	0.2	1 <sup>(2)</sup> (3)		230	4

<sup>(2)</sup> The stone must be positioned on the base of the oven.

<sup>(3)</sup> Frozen pizza baked on stone does not require different baking times depending on the weight.

## PASTA/RICE

Subcategory	Cooking	Weight (Kg)	Level	Function	Temp. (°C)	Time (minutes)
Pasta bake	-	1.9	1		220	35
Lasagne	-	3	1		230	40
Paella	-	0.5	2		190	25
Quiche	-	1	1		200	40

## PIES/FLANS

Subcategory	Cooking	Weight (Kg)	Level	Function	Temp. (°C)	Time (minutes)
Soufflé	-	0.5	2		180	25



## Use

### SLOW COOKING

Subcategory	Cooking	Weight (Kg)	Level	Function	Temp. (°C)	Time (minutes)
Veal	-	1.5	2		90	540
Beef	Rare	1.4	2		90	190
	Well done	1	2		90	480
Pork loin	-	1	2		90	420
Lamb	-	1.5	2		90	480



The cooking times in the table refer to the food indicated in the recipe and are a guide only; they may vary depending on personal taste.



The tables give the factory-set data. To reset a predefined preset recipe with the original settings after it has been modified, just enter the data given in the tables above.



If ECO logic mode (see 3.12 Settings) has been activated, cooking times or preheating times may vary.



### 3.1.1 Personal recipes



This menu allows you to enter a personal recipe with the parameters you wish to use. On first use, the appliance will only offer you to add a new recipe. After saving your recipes, these will then be available in the relative menu.

1. On the clock screen, press the control knob to access the main menu.
2. Turn the control knob to the right or left to select **personal recipes** from the main menu.
3. Press the control knob to confirm.

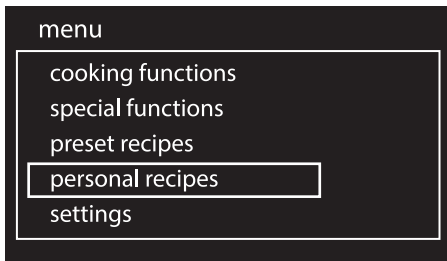

Up to 10 personal recipes can be stored.

### Adding a recipe

1. Select **add** from the “personal recipes” menu.

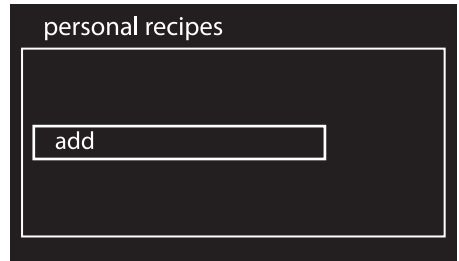

2. Turn the control knob to the right or left to select the **function** to associate with the recipe.



3. Press the control knob to confirm.



## Use

- Turn the control knob to the right or left to select the **weight** of the dish to associate with the recipe.



- Press the control knob to confirm.

**i** The weight can be set or modified up to 5 kg, but the user is responsible for ensuring that the dish will fit correctly inside the oven.

- Turn the control knob to the right or left to select the cooking **duration** to associate with the recipe.



- Press the control knob to confirm.
- Turn the control knob to the right or left to select the cooking **temperature** to associate with the recipe.

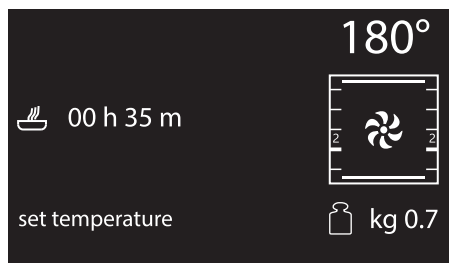

- Press the control knob to confirm.
- Turn the control knob to the right or left to select the **shelf** to associate with the recipe.

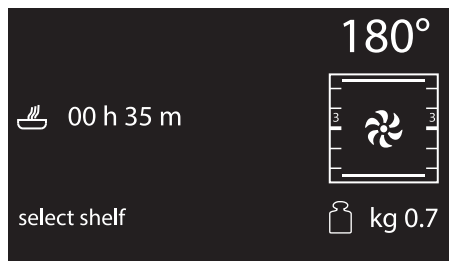



- Press the control knob to confirm.

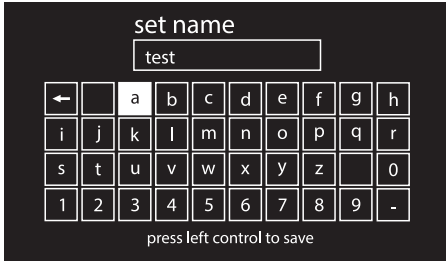

12. Pressing the control knob again will return to point 2 of the change sequence. You must press the return knob to save the recipe. The appliance will ask you to enter a name for the recipe you have just created.





13. Enter the name of the recipe. Turn the control knob to select the characters to enter. Each time the control knob is pressed, a character of the name will be entered. The character  deletes the previous letter.

 The recipe name can contain a maximum 10 characters, including spaces.

 The name must contain at least one character in order to store the recipe.

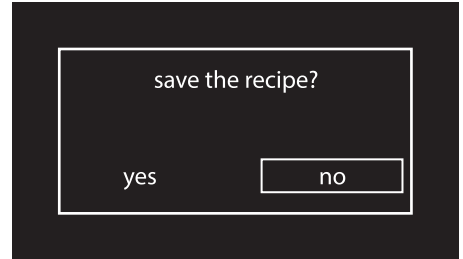
14. After entering the name of your recipe, press the return knob to confirm or cancel the information you have entered. Select **YES** if you wish to store the recipe.



 If you select "NO", you will lose all modifications made.

15. If the change is confirmed the display will show confirmation of this.





## Starting a personal recipe

1. Turn the control knob to the right or left to select a previously stored **personal recipe** from the “personal recipes” menu (in the example, the recipe **test** has been stored).

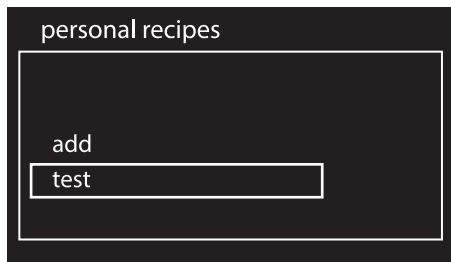

2. Press the control knob to confirm.
3. Turn the control knob to the right or left to select **start**.

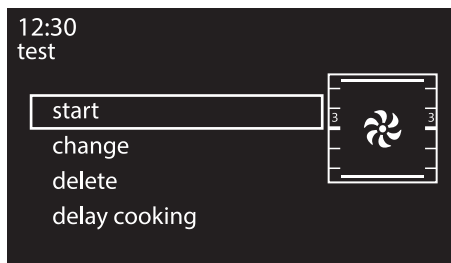

4. Press the control knob to confirm.

Cooking will start with the parameters previously set for the recipe.

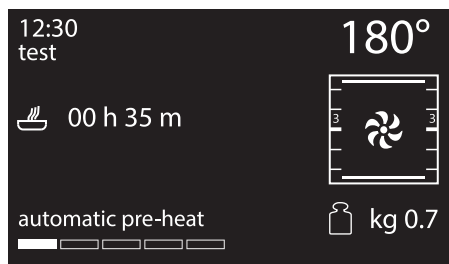

**i** During cooking it is always possible to modify the temperature and cooking time, but this will not be saved to the recipe for future use.

## Modifying a personal recipe

1. Turn the control knob to the right or left to select a previously stored **personal recipe** from the “personal recipes” menu (in the example, the recipe **test** has been stored).

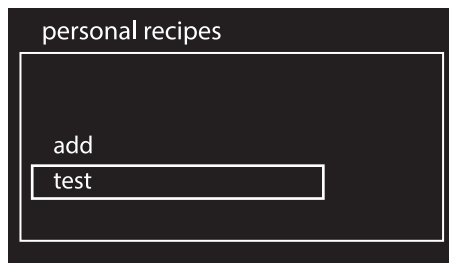



2. Press the control knob to confirm.
3. Turn the control knob to the right or left to select **change**.

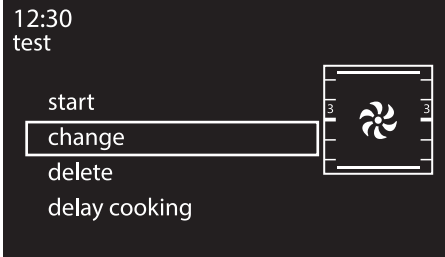

4. Press the control knob to confirm.
5. Repeat the same steps starting from point 2 in chapter "Adding a recipe".

### Deleting a personal recipe

1. Turn the control knob to the right or left to select a previously stored **personal recipe** from the "personal recipes" menu (in the example, the recipe **test** has been stored).

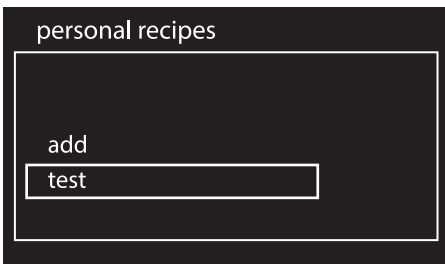

2. Press the control knob to confirm.

3. Turn the control knob to the right or left to select **delete**.

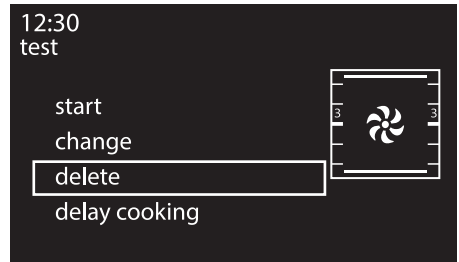

4. Press the control knob to confirm.
5. Confirm the deletion. Select YES to permanently delete the recipe.



6. If you confirm the deletion, the display will show a confirmation message.





## Use

### Delay cooking

1. Turn the control knob to the right or left to select a previously stored **personal recipe** from the “personal recipes” menu (in the example, the recipe **test** has been stored).

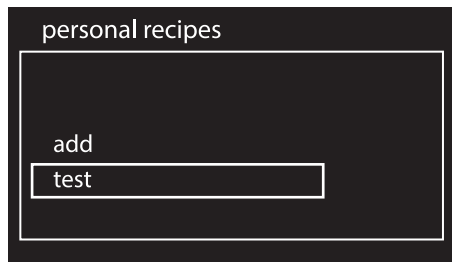

2. Press the control knob to confirm.
3. Turn the control knob to the right or left to select **function delayed**.

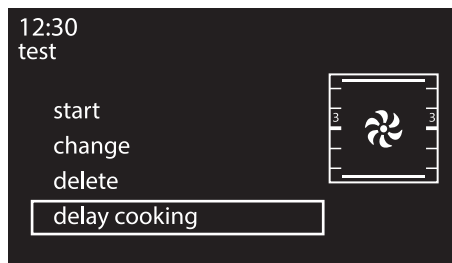

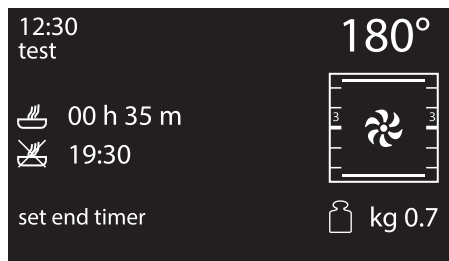

4. Press the control knob to confirm.

5. Turn the control knob to the right or left to select the cooking end time with the control knob. The symbol  flashes.

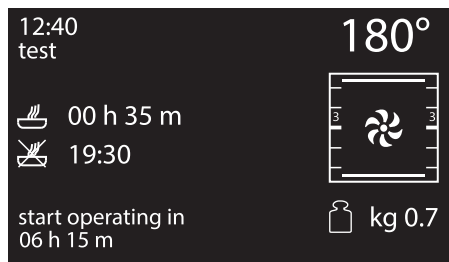

6. Press the control knob to confirm.



After a few seconds the symbol  will stop flashing. The appliance waits for the delay start time.





### 3.12 Settings



The product configuration can be set using this menu.

1. On the clock screen, press the control knob to access the main menu.
2. Turn the control knob to the right or left to select **settings** from the main menu.
3. Press the control knob to confirm.

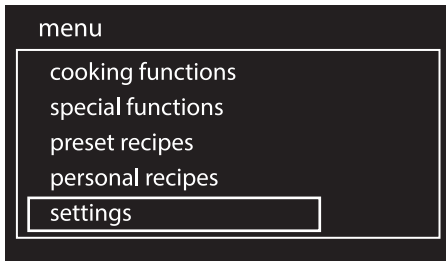

### Language

Sets the interface language from those available.

1. Turn the control knob to the right or left to select **language** from the "settings" menu.

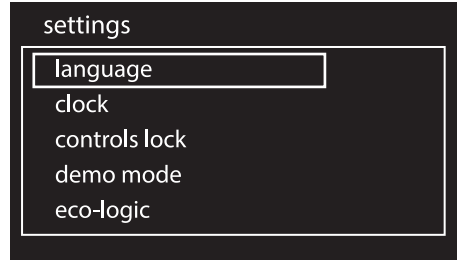

2. Press the control knob to confirm.
3. Turn the control knob to the right or left to select the required language.

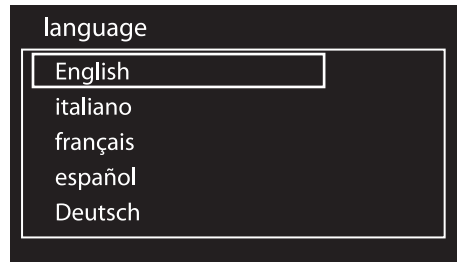

4. Press the control knob to confirm the selected language.



## Clock

Allows you to change time displayed.

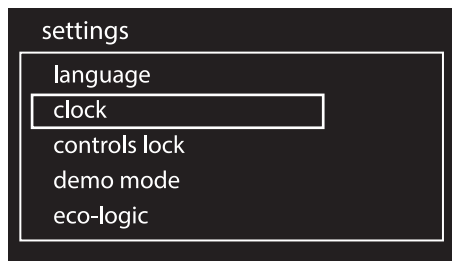

1. Turn the control knob right or left to set the hours.
2. Press the control knob to switch to changing the minutes.
3. Turn the control knob right or left to set the minutes.

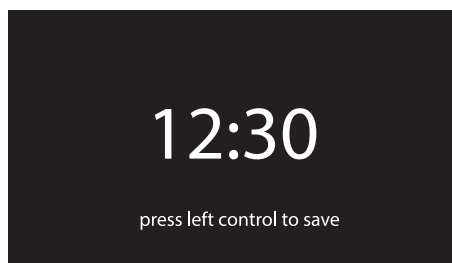

4. Press the return knob to confirm.

## Control lock

Allows the appliance to automatically lock the controls after one minute of normal operation without any intervention from the user.

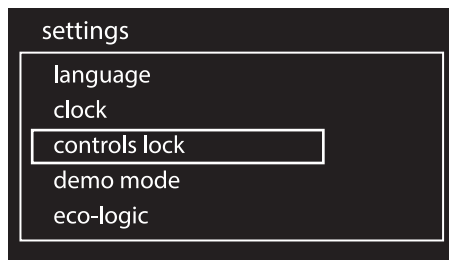

- To confirm activation of the controls lock, select **YES**.

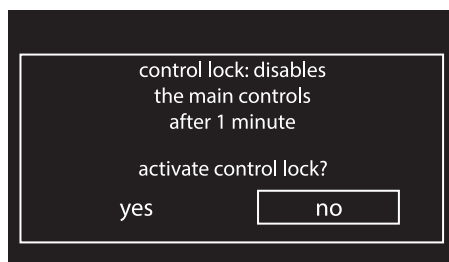

During normal operation it is indicated by the indicator light  coming on.

- To temporarily release the lock during cooking, hold the return knob down for 3 seconds. One minute after the last setting the lock will become active again.



If the control and return knobs are touched or change position, the display will show a warning for two seconds.



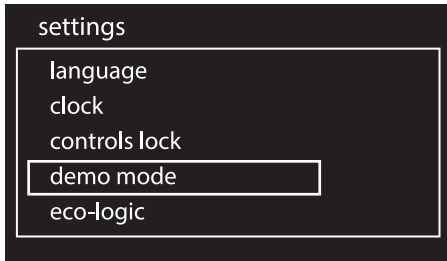

### Demo mode (for showrooms only)

This mode allows the appliance to deactivate all heating elements, while keeping the control panel active.

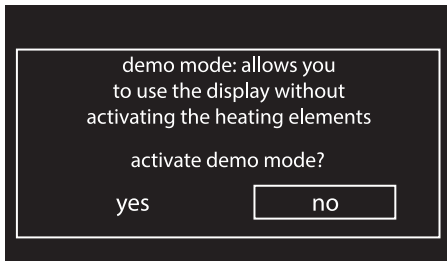

- To confirm the activation of the demo mode, select YES.



 If the mode is active, "demo mode" will be shown on the display.

 To use the appliance normally, set this mode to **OFF**

### Eco-Logic (on some models only)

This mode allows the appliance to limit the power used. Suitable for simultaneous use with further home appliances.

If this option is enabled, the symbol  will appear on the display.

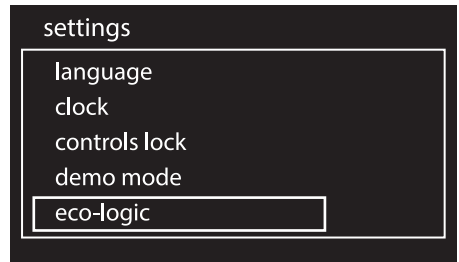

- To confirm the activation of eco-logic mode, select YES.

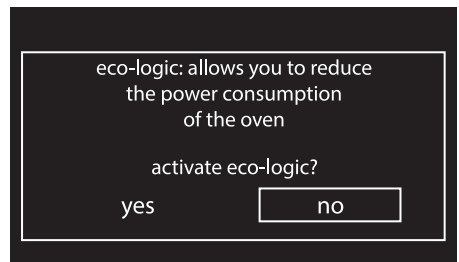

 When eco-logic mode is active, preheating and cooking times may be extended.



## Sound

Whenever one of the knobs is pressed, the appliance beeps. This setting disables these sounds.

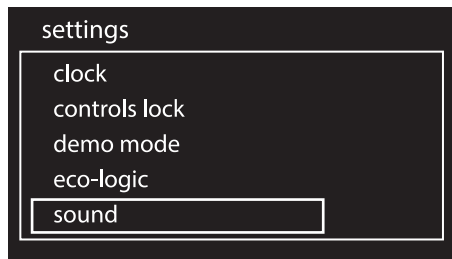

- To disable sounds when the knobs are pressed, select NO.

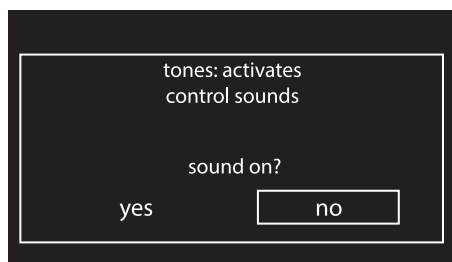

## Keep warm

This mode allows the appliance to keep cooked food warm (at low temperatures) after cooking finishes with a cooking cycle for which a duration has been set (if this is not manually interrupted), without altering the taste and smell obtained during cooking.

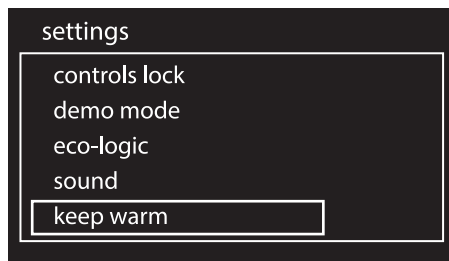

- To confirm the activation of the keep warm function, select YES.

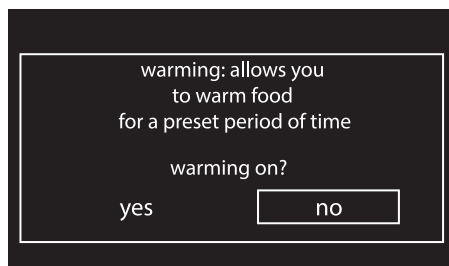

## Eco-Light

For greater energy savings, the light is automatically deactivated one minute from the start of cooking.

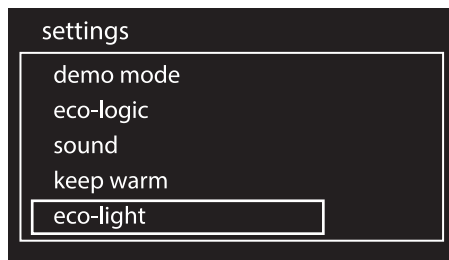



- To confirm the activation of Eco-Light mode, select YES.

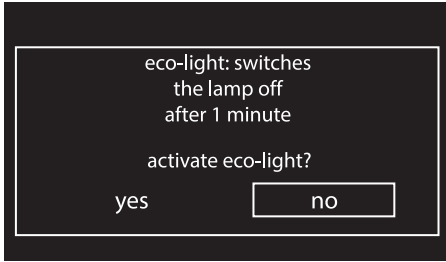

- To stop the appliance from automatically deactivating the light after one minute, set this mode to OFF.

**i** If the Eco-Light function is set to OFF, when the appliance is in standby it displays the current time dimly.

**i** The appliance consumes more energy in stand-by mode when the Eco-Light function is set to OFF.

 The manual on/off control is always available with both settings by turning the return knob to the right.

**i** The Eco-Light mode also turns off the display after 2 minutes of inactivity.

## Digital clock

Displays the time in digital format.

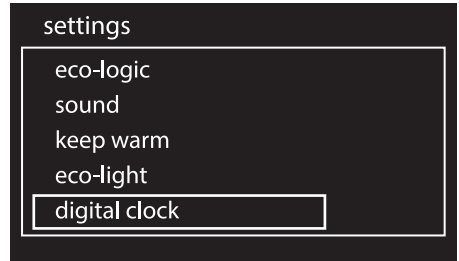

- To confirm the activation of the digital clock, select YES.

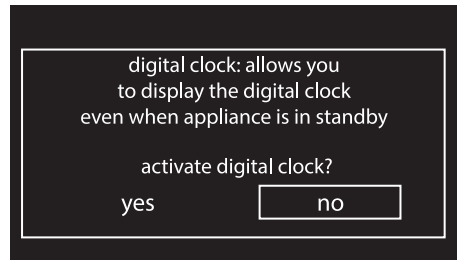

When no appliance function is active, the display will show the current time in digital format.

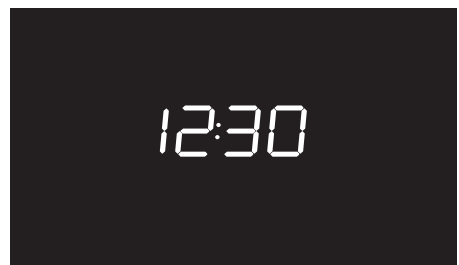



# Cleaning and maintenance

## 4 Cleaning and maintenance

### 4.1 Instructions



#### Improper use Risk of damage to surfaces

- Do not use steam jets to clean the appliance.
- Do not use cleaning products containing chlorine, ammonia or bleach on parts made of steel or that have metallic surface finishes (e.g. anodizing, nickel- or chromium-plating).
- Do not use abrasive or corrosive detergents (e.g. scouring powders, stain removers and metallic sponges) on glass parts.
- Do not use rough or abrasive materials or sharp metal scrapers.
- Do not wash the removable components such as the hob grids, flame-spreader crowns and burner caps in a dishwasher.



We recommend the use of cleaning products distributed by the manufacturer.

### 4.2 Cleaning the hob

To keep the surfaces in good condition, they should be cleaned regularly after use. Let them cool first.

1. Pour some non-abrasive detergent on a damp cloth and wipe the surface.
2. Rinse thoroughly.
3. Dry with a soft cloth or a microfibre cloth.

#### Cleaning the igniters and thermocouples

- If necessary, clean the igniters and thermocouples with a damp cloth.
- If there is any dry residue, remove it with a toothpick or needle.

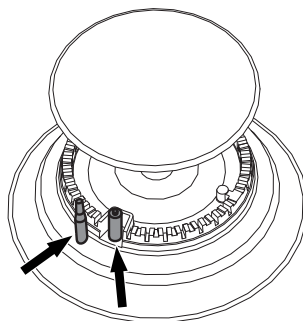



## Cleaning the grids, flame-spreader crowns and burner caps

1. Remove the components from the hob.
2. Clean with lukewarm water and non-abrasive detergent. Make sure to remove any encrustations.
3. Dry thoroughly with a soft cloth or a microfibre cloth.
4. Replace the components on the hob.



The continuous contact between the grids and the flame can cause modifications to the enamel over time in those parts exposed to heat. This is a completely natural phenomenon which has no effect on the operation of this component.

## 4.3 Cleaning the oven cavity

In order to keep your oven in the best possible condition, clean it regularly after letting it cool down.

Avoid letting food residue dry inside the oven cavity, as this could damage the enamel.

Take out all removable parts before cleaning.

For easier cleaning, we recommend removing:

- The door
- The rack/tray support frames
- Removable guides, where fitted
- The seal (pyrolytic models excluded).



In the event you are using specific cleaning products, we recommend running the appliance at maximum temperature for 15-20 minutes in order to eliminate any residue.



## Cleaning and maintenance

### Removing rack/tray support frames (on some models only)

Removing the rack/tray support frames enables the sides to be cleaned more easily.

To remove the rack/tray support frames:

- Pull the frame towards the inside of the oven to unhook it from its groove **A**, then slide it out of the seats **B** at the back.

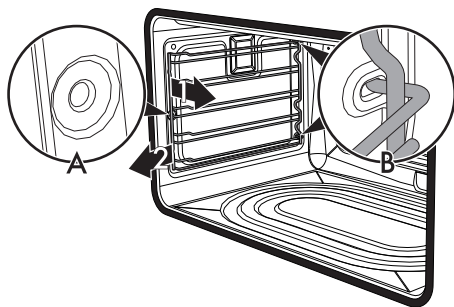

- When cleaning is complete, repeat the above procedures to put the rack/tray support frames back in.

### Removing the side self-cleaning panels and rack/tray support frames (pyrolytic models excluded)

Removing the side self-cleaning panels and the rack/tray support frames enables the sides to be cleaned more easily.

To remove the self-cleaning panels and rack/tray support frames:

- Pull the frame towards the inside of the oven to unhook it from its groove **A**, then slide it out of the seats **B** at the back. The side self-cleaning panel is attached to the rack/tray support frame.

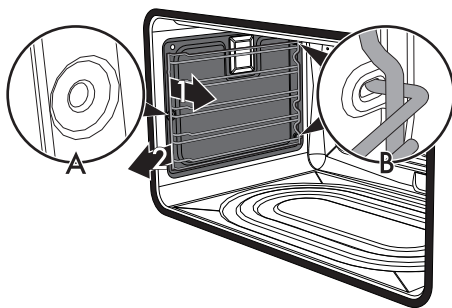

During the removal take care not to detach the self-cleaning panel from the rack/tray support frame accidentally to avoid damaging the surfaces.

- When cleaning is complete, repeat the above procedures to put the side self-cleaning panels and rack/tray support frames back in.





## Regeneration of self-cleaning panels (catalysis cycle) (pyrolytic models excluded)

The regeneration cycle of the self-cleaning panels is a cleaning method through heating suitable for removing small grease residues, not sugar-based ones.

1. Clean the base and the upper section first with a microfibre cloth soaked in water and neutral washing up liquid. Rinse thoroughly.
2. Set a regeneration cycle by selecting a fan assisted function at the maximum temperature for one hour.
3. If the panels are particularly dirty after the regeneration cycle, remove them and wash them with neutral washing up liquid. Rinse and dry them.
4. Put the panels back in the oven and set a fan assisted function at a temperature of 180 °C for one hour, in order to ensure that they are thoroughly dry.



We recommend carrying out the self-cleaning panel regeneration cycle every 15 days.

## Cleaning of the upper part (pyrolytic models excluded)

The oven cavity is fitted with a tilting heating element which facilitates cleaning the top part (roof) of the oven.

1. Free the upper heating element by gently lifting it and rotating its retainers by 90 degrees.

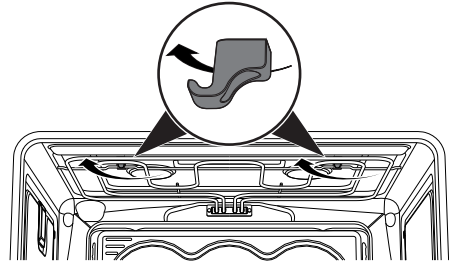

2. Gently lower the heating element until it stops.

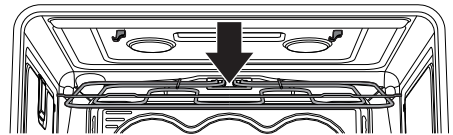

**Improper use**

**Risk of damage to the appliance**

- Do not excessively flex the element during cleaning.
3. When you have finished cleaning, place the heating element back in position and turn the retainers to lock it in place again.



## Cleaning and maintenance

### Manual deactivation of the door lock lever (pyrolytic models only)



**Improper use  
Danger of burns**

- The following operations must always be performed with the appliance cold and switched off.
- Never attempt to manually deactivate the door lock lever during a pyrolytic cycle.

The door lock lever is located in the left slot on the left under the control panel, in the upper part of the front of the oven.

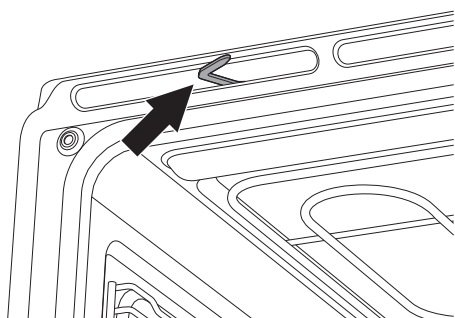

During normal cleaning operations, it is possible to accidentally activate the door lock lever.

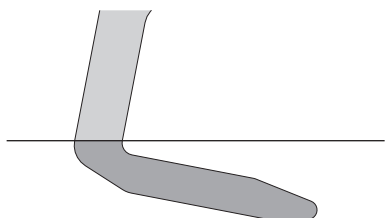

**Door lock lever activated**

**(view from above)**

1. Move the door lock lever to the right until it stops.

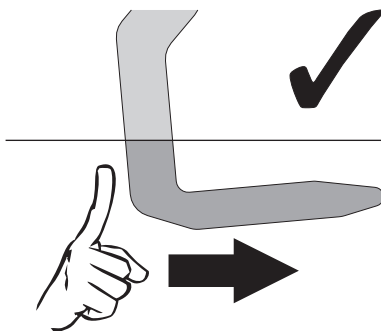

**(view from above)**

2. Gently release the door lock lever.

The mechanism's spring will return the door lock lever to the deactivated position.

To prevent damage to the mechanism, never attempt to deactivate the door lock lever by forcing it to the left.

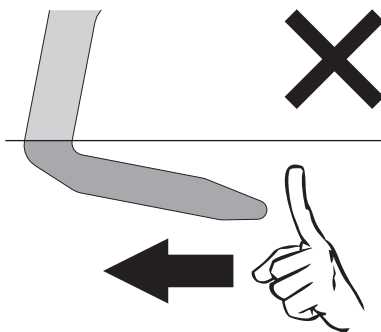

**(view from above)**



## 4.4 Vapor Clean (on some models only)

**i** Vapor Clean is an assisted cleaning procedure which facilitates the removal of dirt. This process makes it possible to clean the inside of the oven very easily. The dirt residues are softened by the heat and steam, making them easier to remove afterwards.

**!** **Improper use**  
**Risk of damage to surfaces**

- Remove any large amounts of food residues or spills from previous cooking operations from the inside of the oven.
- Carry out assisted oven cleaning operations only when the oven is cold.

### Preliminary operations

Before starting the Vapor Clean cycle:

- Completely remove all accessories from inside the oven. The upper guard can be left inside the oven cavity.
- Remove the self-cleaning panels (see "Removing the side self-cleaning panels and rack/tray support frames (pyrolytic models excluded)").

- Pour approx. 40 cc of water onto the floor of the oven. Make sure it does not overflow out of the cavity.

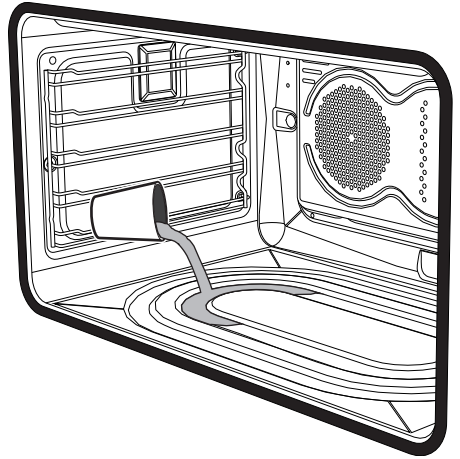

- Spray a water and washing up liquid solution inside the oven using a spray nozzle. Direct the spray against the side walls, upwards, downwards and towards the deflector.

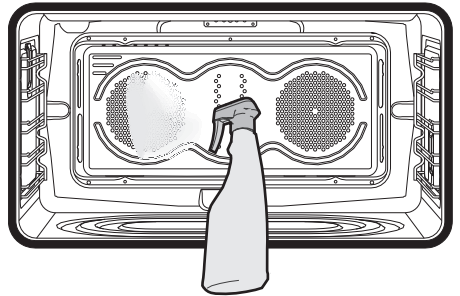

- Close the door.



We recommend spraying approx. 20 times at the most.



## Cleaning and maintenance

- During the assisted cleaning cycle, wash the self-cleaning panels (if available) which were previously removed separately with warm water and a small amount of detergent.

### Vapor Clean cycle setting



If the internal temperature is greater than that required for the Vapor clean function, the cycle will be stopped immediately and "Internal temperature unsafe, please wait until the oven is cool" will appear on the display. Leave the appliance to cool down before activating the assisted cleaning cycle.

1. Turn the control knob to the right or left to select the **Vapor Clean** function from the "special functions" menu. Then press it to confirm.

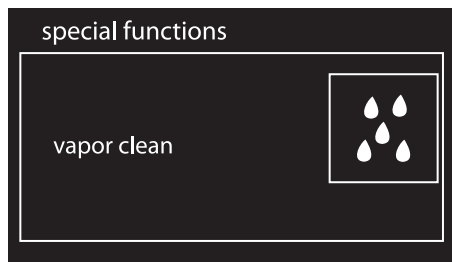

2. The duration and temperature of the cleaning cycle will appear on the display.

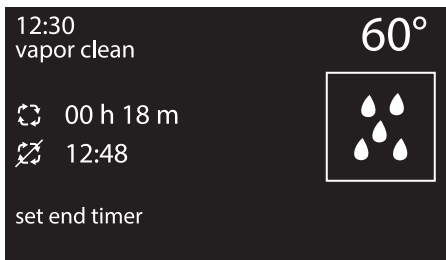

The duration and temperature parameters cannot be changed by the user.

3. Press the control knob twice to start the cleaning cycle.

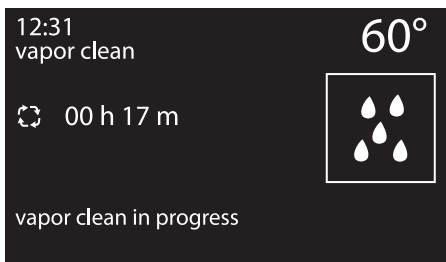

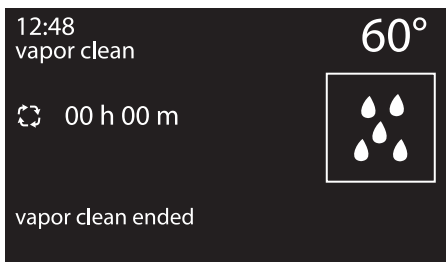

4. A buzzer will indicate the end of the vapour clean cycle.





## Setting the programmed Vapor Clean cycle

It is possible to program the Vapor Clean cycle start time, like any cooking function.

1. After selecting the Vapor Clean special function, press the control knob. The display shows the current time and the  symbol comes on.
2. Turn the control knob to set the time you wish the Vapor Clean cycle to finish.
3. After a few seconds, the symbols  and  remain lit steadily and the appliance waits for the set start time in order to start the cleaning cycle.

## End of the Vapor Clean cycle

1. Open the door and wipe away the less stubborn dirt with a microfibre cloth.
2. Use a non-scratch sponge with brass filaments on hard to remove deposits.
3. In case of grease residues use specific oven cleaning products.
4. Remove any remaining water from the oven.

For greater hygiene and to avoid food being affected by any unpleasant odours, we recommend that the oven is dried using a fan-assisted function at 160 °C for approximately 10 minutes.



We recommend wearing rubber gloves for these operations.



For easier manual cleaning of parts that are difficult to reach, we recommend removing the door.



## Cleaning and maintenance

### 4.5 Pyrolytic (on some models only)



Pyrolytic is an automatic high-temperature cleaning procedure which causes dirt to dissolve. This process makes it possible to clean the inside of the oven very easily.



#### Improper use Risk of damage to surfaces

- Remove any large amounts of food residues or spills from previous cooking operations from the inside of the oven.
- Switch off the burners or electric hot plates of the hob installed above the appliance.

#### Preliminary operations

Before starting the pyrolytic cycle:

- Clean the internal glass pane following the usual cleaning instructions.
- For very stubborn encrustations spray an oven cleaning product onto the glass (read the warnings on the product); leave for 60 minutes, then rinse and dry the glass using kitchen roll or a microfibre cloth.

- Completely remove all accessories from inside the oven.
- Remove the rack/tray support frames.
- Remove the upper guard (when fitted).
- Close the door.

#### Pyrolytic function setting

1. Turn the control knob to the right or left to select **ECO pyrolytic** or **pyrolytic** from the "special functions" menu. Then press it to confirm.

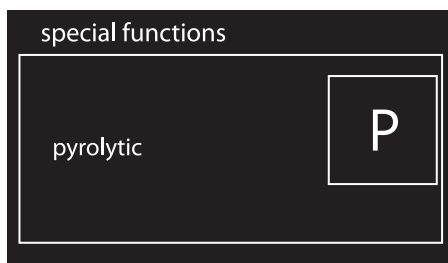
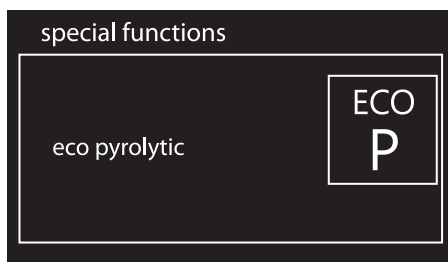

# Cleaning and maintenance



- Turn the control knob to set the cleaning cycle duration from a minimum of 2 hours to a maximum of 3 hours (except for the **ECO P** function whose duration is 2 hours).

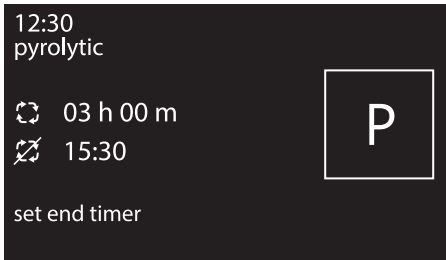
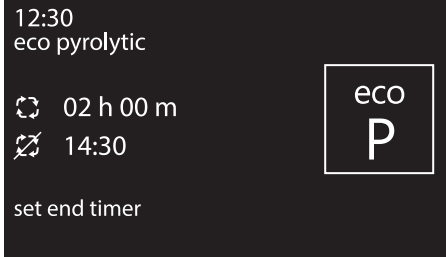

- Press the control knob. The  symbol will now be lit solidly. The display will show a warning to remove accessories from inside the oven cavity.

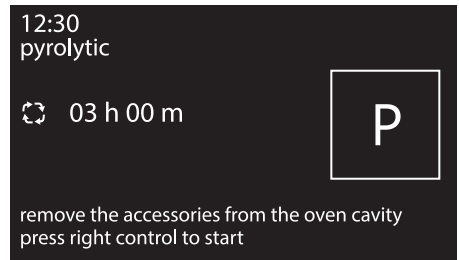
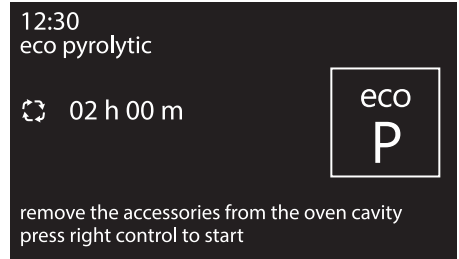

- Press the control knob to start the pyrolytic cycle.



Recommended pyrolytic cycle duration:

- Light dirt: 2 hours.
- Medium dirt: 2 hours and ½.
- Heavy dirt: 3 hours.

EN



## Cleaning and maintenance

### Pyrolytic cycle

1. The display shows “cleaning in progress” and the remaining time to indicate that the appliance is carrying out the automatic cleaning cycle. Two minutes after the pyrolytic cycle has started the door is locked (the symbol  is displayed) by a device that prevents the door from being opened.

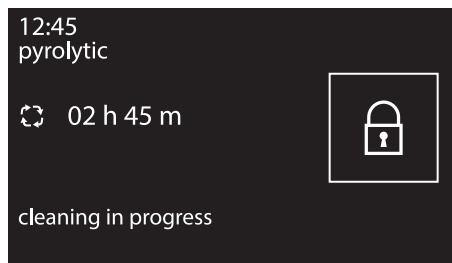
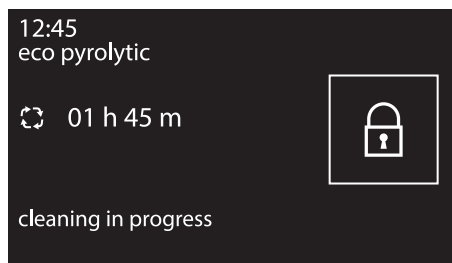

2. At the end of the pyrolytic cycle, the door remains locked as long as the temperature inside the oven returns to safety levels.

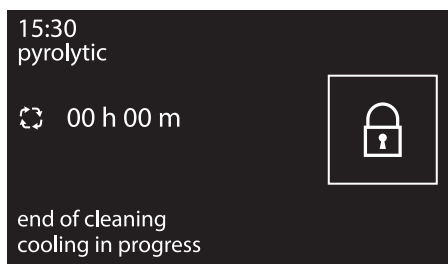
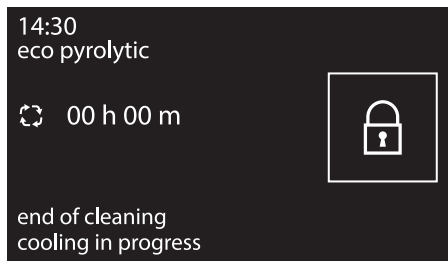

3. The display will indicate that the cooling procedure is in progress.



It is not possible to select any function once the door lock device has been activated.





4. Wait for the appliance to cool down and collect the residues deposited inside with a damp microfibre cloth.



During the first pyrolytic cycle, unpleasant odours may occur due to the normal evaporation of oily manufacturing substances. This is an absolutely normal phenomenon which disappears after the first pyrolytic cycle.





During the pyrolytic cycle the fans produce a more intense level of noise due to a greater rotation speed. This is an absolutely normal operation, intended to provide more effective heat dispersal. At the end of the pyrolytic cycle, the fans will continue to operate for long enough to avoid overheating the walls of adjacent units and the front of the oven.



If the pyrolytic cycle gives unsatisfactory results at minimum duration, it is recommended to set a longer time for successive cleaning cycles.

## Setting of programmed pyrolytic cycle

It is possible to program the pyrolytic cycle start time like all other cooking functions.

1. After selecting the pyrolytic cycle duration, press the control knob. The display shows the current time and the  symbol comes on.
2. Turn the control knob to set the time you wish the pyrolytic cycle to finish.
3. After a few seconds, the symbols  and  remain lit steadily and the appliance waits for the set start time in order to start the cleaning cycle.



It is not possible to select any function once the door lock device has been activated. It remains possible, however, to switch off the appliance using the specific controls.



## Cleaning and maintenance

### 4.6 Removing the door

For easier cleaning it is recommended to remove the door and place it on a tea towel.

To remove the door proceed as follows:

1. Open the door completely and insert two pins into the holes on the hinges indicated in the figure.

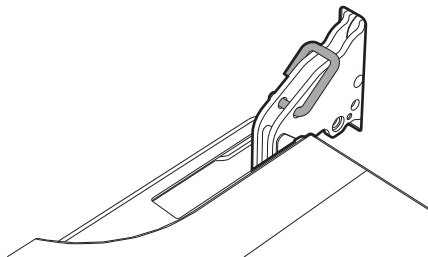

2. Grasp the door on both sides with both hands, lift it forming an angle of around 30° and remove it.

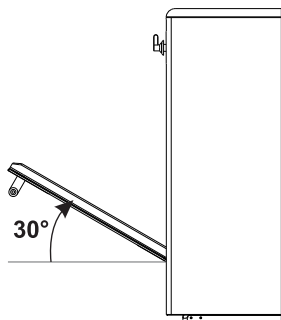

3. To reassemble the door, put the hinges in the relevant slots in the oven, making sure that grooved sections **A** are resting completely in the slots. Lower the door and once it is in place remove the pins from the holes in the hinges.

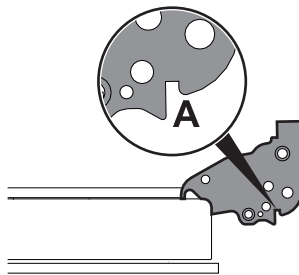

### 4.7 Cleaning the door glazing

The door glazing should always be kept thoroughly clean. Use absorbent kitchen roll. In case of stubborn dirt, wash with a damp sponge and an ordinary detergent.



## Removing internal glazing (multifunction model)

For easier cleaning the internal glazing panes of the door can be removed.

1. Open the door.
2. Position the locking hooks in the hinge holes to prevent accidental closing of the door.
3. Remove the internal glazing pane by pulling the rear part gently upwards, following the movement indicated by the arrows (1).

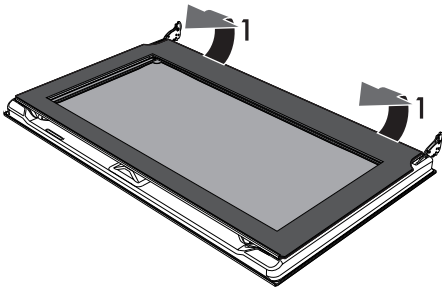

4. Pull the internal glazing pane from the front strip (2) to remove it from the door.

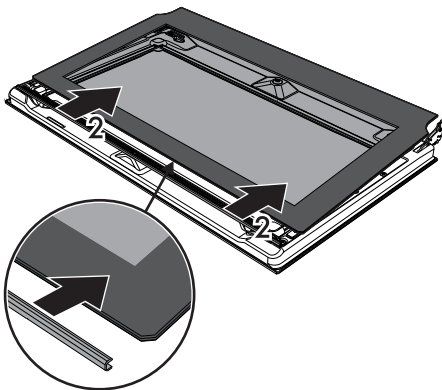

5. Remove the intermediate glazing pane by lifting it upwards.

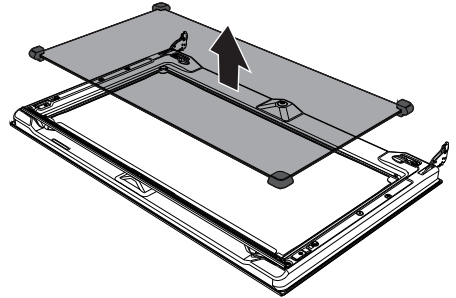

6. Clean the external glazing pane and the panes removed previously. Use absorbent kitchen roll. In case of stubborn dirt, wash with a damp sponge and neutral detergent.

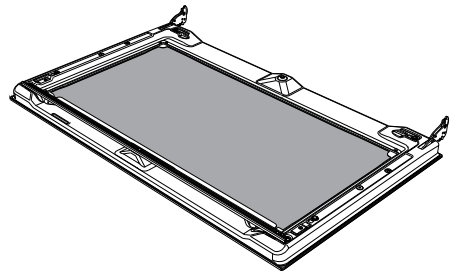

7. When you have finished cleaning, reinsert the intermediate glazing pane in its housing in the door.
8. To reposition the internal glazing pane, slide the upper part into the door strip and insert the two rear pins into their seats by pressing lightly.



## Cleaning and maintenance

### Removing the internal door glazing (pyrolytic model)

For easier cleaning the internal glazing panes of the door can be removed.

1. Open the door.
2. Position the locking hooks in the hinge holes to prevent accidental closing of the door.
3. Remove the internal glazing pane by pulling the rear part gently upwards, following the movement indicated by the arrows (1).

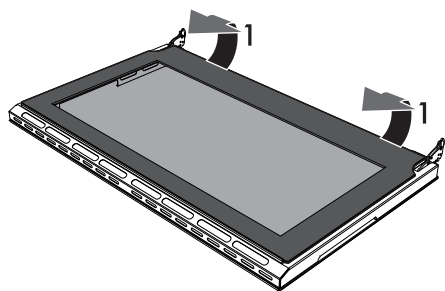

4. Pull the internal glazing pane from the front strip (2) to remove it from the door.

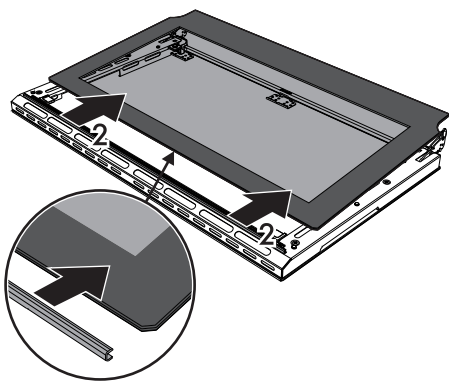

5. Remove the middle glazing panes by lifting them upwards.

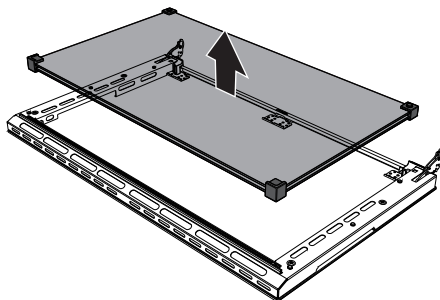

6. Clean the external glazing pane and the panes removed previously. Use absorbent kitchen roll. In case of stubborn dirt, wash with a damp sponge and neutral detergent.

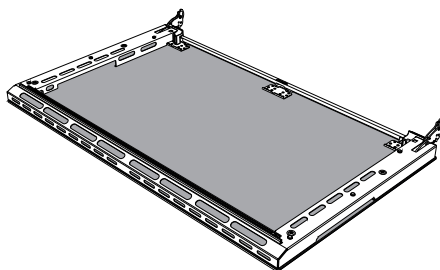

7. When you have finished cleaning, reinsert the intermediate glazing pane in its housing in the door.
8. To reposition the internal glazing pane, slide the upper part into the door strip and insert the two rear pins into their seats by pressing lightly.



## 4.8 Extraordinary maintenance

### Replacing the internal light bulb



Live parts

**Danger of electrocution**

- Unplug the appliance.



The oven is fitted with a 40 W light bulb.

1. Completely remove all accessories from inside the oven.
2. Remove the rack/tray support frames.
3. Remove the bulb cover using a tool (e.g. a screwdriver).



Pay attention not to scratch the oven cavity enamel.

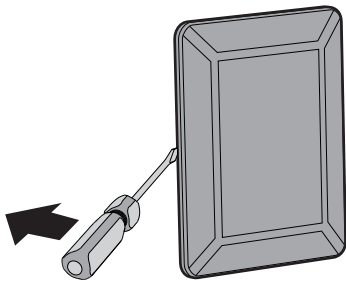

4. Slide out and remove the light bulb.

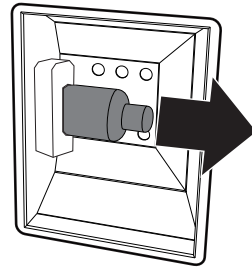

Do not touch the halogen light bulb directly with your fingers, but wrap it in insulating material.

5. Fit the new light bulb.
6. Refit the cover. Ensure the moulded part of the glass (A) is facing the door.

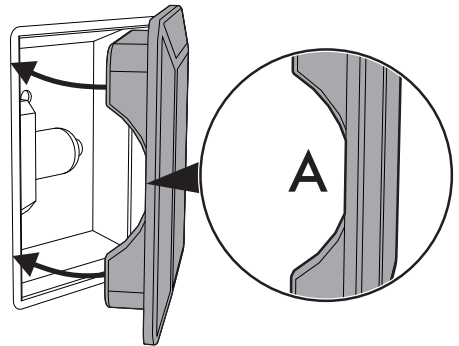

7. Press the cover completely down so that it attaches perfectly to the bulb support.



## Cleaning and maintenance

### Removing and installing the door seal (not on pyrolytic models)

To remove the seal:

- Unhook the clips located in the 4 corners and in the centre, then pull the seal outwards.

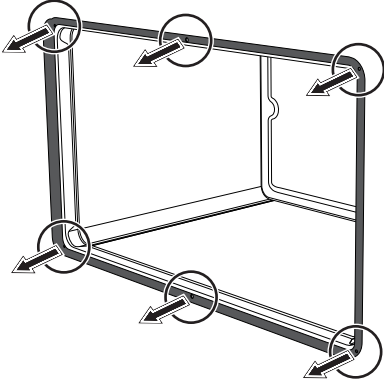

To refit the seal:

- Hook the clips located in the 4 corners and in the centre onto the seal.

### Seal maintenance tips

The seal should be soft and elastic.

- To keep the seal clean, use a non-abrasive sponge and wash with lukewarm water.

### What to do if...

The appliance does not work:

- The switch is defective: check the fuse box and check that the switch is in order.
- Drop in power: check that the appliance's indicator lights are working.

The gas burner does not light up:

- Loss of power or moisture in the igniters: light the gas burner with a lighter or match.

The oven does not heat up:

- Fuse defective; check and, if necessary, replace the switch.
- The function knob has not been set: set the function knob.
- Check whether it has been set in "demo" mode (for further details see "Preset recipes").

All food prepared in the oven burns within a short time:

- Defective thermostat: contact an Authorised Service Centre

The door glazing steams up when the oven is hot:

- Absolutely normal behaviour caused by the temperature difference: this has no effect on the performance of the oven.



## The display is completely off:

- Check the mains power supply.
- Check whether an all-pole disconnection switch upstream of the appliance supply line is in the "ON" position.

## The controls do not respond:

- Check whether it has been set in "controls lock" mode (for further details see "Preset recipes").

## The cooking times are longer than those indicated in the table:

- Check whether it has been set in "ecologic" mode (for further details see "Preset recipes").

## The display shows "ERR4":

- The door lock has not properly attached to the door. This might be because the door was accidentally opened during the door lock activation. Switch the appliance off and on again, waiting a few minutes before selecting a new cleaning cycle.

## If the door is opened during a fan assisted function, the fan stops:

- This is not a fault. It is a normal operation of the appliance, useful when cooking foods in order to avoid excessive heat escaping. When the door is closed, the oven will return to normal operation.

## (pyrolytic models only) After the (pyrolytic) automatic cleaning cycle it is not possible to select a function:

- Verify whether the door lock has deactivated. If it has not, the appliance is fitted with a safety device that does not allow functions to be selected while the door lock is active. This is because the temperature inside the oven is still too high to permit any type of cooking.



If the problem has not been resolved or in the case of other types of fault, contact your local technical support centre.



If other ERRx error messages are indicated:

Note down the error message, function and set temperature and contact your local technical support centre.



# Installation

## 5 Installation

### 5.1 Gas connection (not valid for the UK)



For installation in the UK, please refer to the "Local specifications for UK gas appliances installation" booklet.



#### Gas leak Danger of explosion

- After carrying out any operation, check that the tightening torque of gas connections is between 10 Nm and 15 Nm.
- If required, use a pressure regulator that complies with current regulations.
- At the end of the installation, check for any leaks with a soapy solution, never with a flame.
- Installation using a hose must be carried out so that the length of the hose does not exceed 2 metres when fully extended for steel hoses and 1.5 metres for rubber hoses.
- The hoses should not come into contact with moving parts and should not be crushed in any way.

### Connection with a rubber hose

Verify that all following conditions are met:

- the hose is fixed to the hose connection with safety clamps;
- no part of the hose is in contact with hot walls (max. 50 °C);
- the hose is not under traction or tension and has no kinks or twists;
- the hose is not in contact with sharp objects or sharp corners;
- if the hose is not perfectly airtight and leaks gas, do not try to repair it; replace it with a new hose.
- Check that the hose is not past its expiry date (printed on the hose itself).

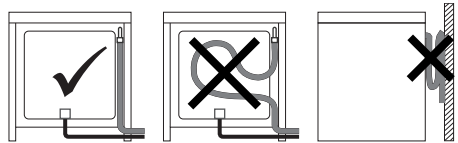

Connection to the gas mains can be made using a continuous wall steel hose in compliance with the guidelines established by the standards in force. For supplying it with other types of gas, see chapter "Adaptation to different types of gas". The gas inlet connection is threaded 1/2" external gas (ISO 228-1).





Make the connection to the gas mains using a rubber hose whose specifications comply with current standards (verify that the reference standard is stamped on the hose).

Carefully screw the hose connector **3** to the appliance's gas connector **1** ( $\frac{1}{2}$ " thread ISO 228-1), placing the seal **2** between them. The hose connector **4** can also be screwed to the hose connector **3**, depending on the diameter of the gas hose used.

After tightening the hose connector(s), push the gas hose **6** onto the hose connector and secure it with the clamp **5**, which must be compliant with applicable regulations.

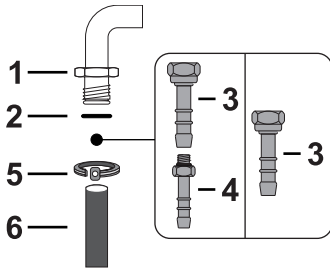

## Connection with a steel hose

Make the connection to the gas mains using a continuous wall steel hose whose specifications comply with the applicable standard.

Carefully screw the connector **3** to the gas connector **1** of the appliance, placing the seal **2** between them.

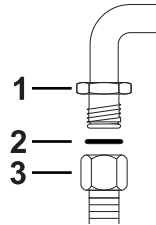

## Connection with a steel hose with bayonet fitting

Carry out the connection to the gas mains using a steel hose with bayonet fitting compliant with B.S. 669. Apply insulating material to the thread of the gas hose connector **4** and then tighten the adapter **3**. Screw the assembly to the movable connector **1** of the appliance, placing the supplied seal **2** between them.

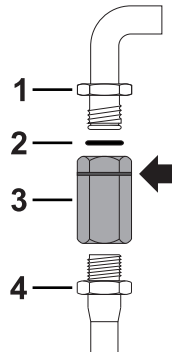

Connection using a rubber hose complying with current standards is only permitted if the hose can be inspected along its entire length.



The inside diameter of the hose must be 8 mm for LPG and 13 mm for Natural gas and Town gas.



# Installation

## Connection with a steel hose with conical fitting

Make the connection to the gas mains using a continuous wall steel hose whose specifications comply with the applicable standard.

Carefully screw the hose connector **3** to the appliance's gas connector **1** (1/2" thread ISO 228-1), placing the supplied seal **2** between them. Apply insulating material to the thread of connector **3**, then tighten the steel hose **4** to the connector **3**.

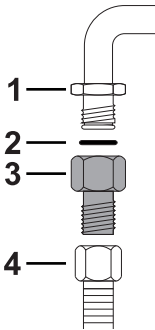

## Connection to LPG

Use a pressure regulator and make the connection on the gas cylinder, following all applicable standards and regulations.

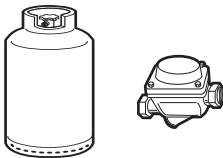

The supply pressure must comply with the values indicated in the table in "Positioning".

## Gas connection extension cord (pyrolytic models only)

For pyrolytic models, the supplied gas connection extension cord must be installed:

1. Undo the screw **A** at the back of the appliance, under the gas connection.
2. Use the just removed screw **A** to fasten the supplied bracket **B** to the back of the cabinet.

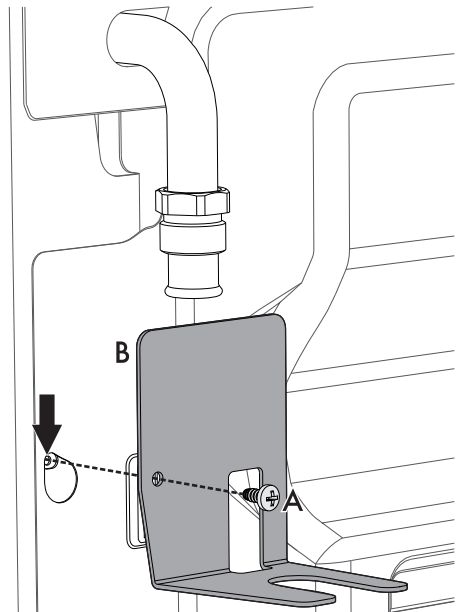



- Carefully screw the connector **3** to the gas extension cord **1** of the appliance, placing the seal **2** between them.

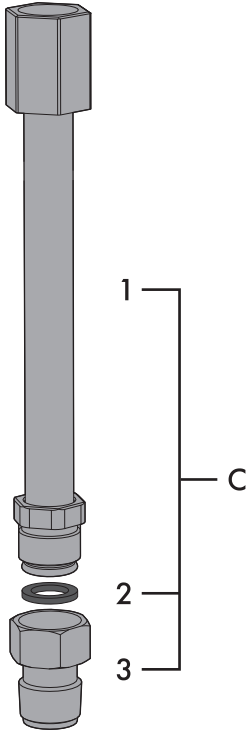

- Carefully screw the assembled extension cord **C** to the gas connector **D** of the appliance, placing the seal **2** between them.

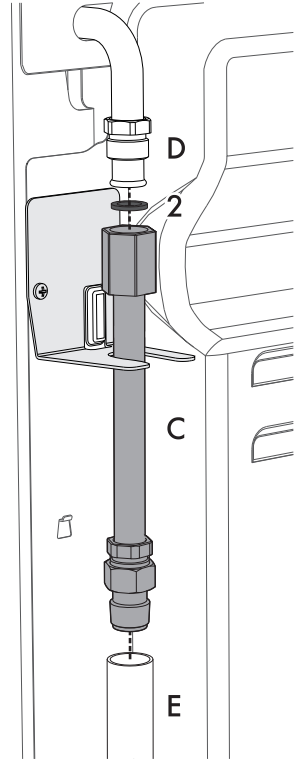

- Apply some insulating material on the thread of the assembled extension cord **C**, then tighten the hose **E**.



# Installation

## Room ventilation

The appliance should be installed in rooms that have a permanent air supply in accordance with the standards in force. The room where the appliance is installed must have enough air flow for the regular combustion of gas and the necessary air change in the room itself. The air vents, protected by grilles, must be the right size to comply with current regulations and positioned so that no part of them is obstructed, not even partially.

The room must be kept adequately ventilated in order to eliminate the heat and humidity produced by cooking: In particular, after prolonged use, you are recommended to open a window or to increase the speed of any fans.

## Extraction of the combustion products

The combustion products may be extracted by means of hoods connected to a natural draught chimney whose efficiency is certain or via forced extraction. An efficient extraction system requires precision planning by a specialist qualified in this area and must comply with the positions and clearances indicated by the applicable standards.

When the job is complete, the installer must issue a certificate of conformity.

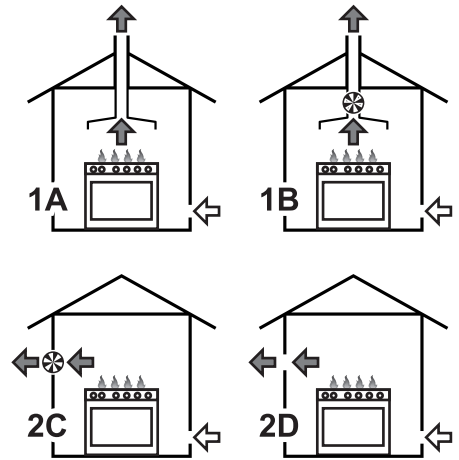

1 Extraction using a hood

2 Extraction without a hood

A Single natural draught chimney

B Single chimney with extractor fan

C Directly outdoors with wall- or window-mounted extractor fan

D Directly outdoors through wall

Air

Combustion products

Extractor fan



## Adaptation to different types of gas

In case of operation with other types of gas, the burner nozzles must be changed and the minimum flame adjusted on the gas cocks.

### Replacing nozzles

1. Remove the grids, burner caps and flame-spreader crowns to access the burner cups.
2. Replace the nozzles using a 7 mm spanner according to the gas to be used (see 5.2 Positioning).

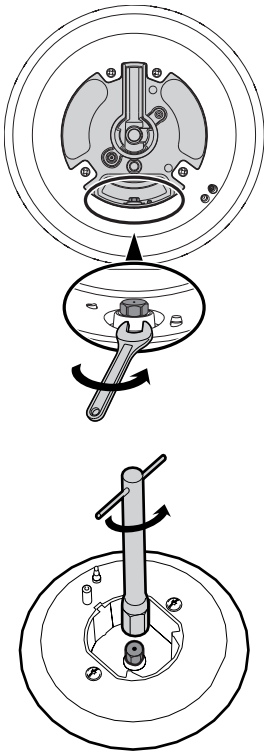

## Adjusting the minimum setting for natural or town gas

Light the burner and turn it to the minimum position. Extract the gas cock knob and turn the adjustment screw next to the tap rod (depending on the model) until the correct minimum flame is achieved.

Refit the knob and verify that the burner flame is stable. Turn the knob rapidly from the maximum to the minimum setting: The flame should not go out. Repeat the operation on all gas cocks.

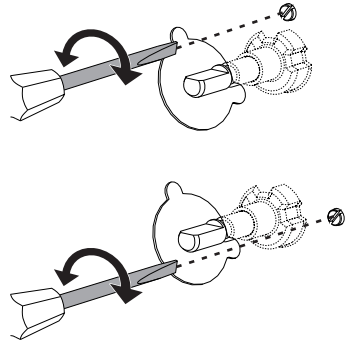

3. Replace the burners in their respective housings.



# Installation

## Adjusting the minimum setting for LPG

Tighten the screw located at the side of the cock rod clockwise all the way.



Following adjustment to a gas other than the one originally set in the factory, replace the gas setting label on the appliance with the one corresponding to the new gas. The label is inserted inside the nozzle pack (where present).

## Lubricating the gas cocks

Over time the gas cocks may become difficult to turn and get blocked. Clean them internally and replace the lubrication grease.



Lubrication of the gas cocks should be performed by a specialised technician.

## Appliance dimensions

Position of gas and electrical connections.

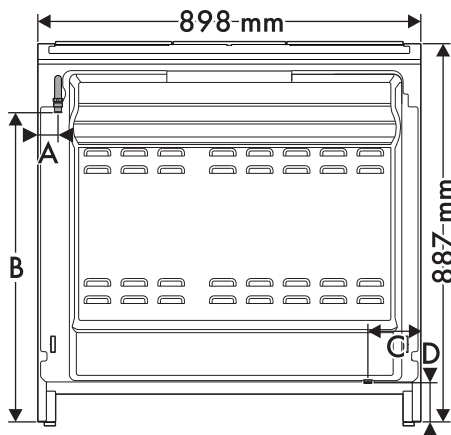

A	48 mm
B	738 mm
C	124 mm
D	97 mm



## Gas types and Countries

Gas types		IT	GB-IE	FR-BE	DE	AT	ES	PT	SE	RU	DK	PL	HU
<b>1 Natural Gas G20</b>													
G20	20 mbar	•	•		•	•	•	•	•	•	•	•	
G20/25	20/25 mbar			•									
<b>2 Natural Gas G20</b>													
G20	25 mbar												•
<b>3 Natural Gas G25.1</b>													
G25.1	25 mbar												•
<b>4 Natural Gas G25</b>													
G25	20 mbar				•								
<b>5 Natural Gas G2.350</b>													
G2.350	13 mbar											•	
<b>6 LPG G30/31</b>													
G30/31	28/37 mbar		•	•			•			•			
G30/31	30/37 mbar	•						•					
G30/31	30/30 mbar								•		•		
<b>7 LPG G30/31</b>													
G30/31	37 mbar											•	
<b>8 LPG G30/31</b>													
G30/31	50 mbar				•	•							
<b>9 Town gas G110</b>													
G110	8 mbar	•							•		•		



It is possible to identify the available gas types based on the country the appliance is to be installed in. Refer to the heading number to identify the correct values in the "Positioning".



# Installation

## Burner and nozzle characteristics tables

1 NATURAL gas – G20 20 mbar	AUX	SR	R	UR2
Rated heating capacity (kW)	1.0	1.8	3.0	4.2
Nozzle diameter (1/100 mm)	72	97	120	145
Pre-chamber (printed on nozzle)	(X)	(Z)	(H9)	(F3)
Reduced flow rate (W)	400	500	800	1200
2 Natural gas G20 – 25 mbar	AUX	SR	R	UR2
Rated heating capacity (kW)	1.1	1.8	2.9	4.1
Nozzle diameter (1/100 mm)	72	94	110	145
Pre-chamber (printed on nozzle)	(X)	(Z)	(H8)	(H3)
Reduced flow rate (W)	400	500	800	1200
3 Natural gas G25.1 – 25 mbar	AUX	SR	R	UR2
Rated heating capacity (kW)	1.1	1.8	3.1	4.1
Nozzle diameter (1/100 mm)	77	100	134	152
Pre-chamber (printed on nozzle)	(F1)	(Y)	(F3)	(F3)
Reduced flow rate (W)	400	500	800	1200
4 Natural gas G25 – 20 mbar	AUX	SR	R	UR2
Rated heating capacity (kW)	1.0	1.8	3.0	4.0
Nozzle diameter (1/100 mm)	77	100	134	165
Pre-chamber (printed on nozzle)	(F1)	(Y)	(F3)	(H3)
Reduced flow rate (W)	400	500	800	1200
5 Natural gas G2.350 – 13 mbar	AUX	SR	R	UR2
Rated heating capacity (kW)	1.0	1.8	2.9	3.8
Nozzle diameter (1/100 mm)	94	120	165	190
Pre-chamber (printed on nozzle)	(Y)	(Y)	(F3)	(F3)
Reduced flow rate (W)	400	500	800	1200
6 Liquid gas – G30/31 - 30/37 mbar	AUX	SR	R	UR2
Rated heating capacity (kW)	1.0	1.75	3.0	4.0
Nozzle diameter (1/100 mm)	50	65	85	100
Pre-chamber (printed on nozzle)	-	-	-	-
Reduced flow rate (W)	400	500	800	1300
Rated flow rate G30 (g/h)	73	127	218	291
Rated flow rate G31 (g/h)	71	125	214	286



# Installation



7 LPG G30/31 - 37 mbar	AUX	SR	R	UR2
Rated heating capacity (kW)	1.1	1.9	3.0	4.2
Nozzle diameter (1/100 mm)	50	65	81	95
Pre-chamber (printed on nozzle)	-	-	-	-
Reduced flow rate (W)	450	550	900	1500
Rated flow rate G30 (g/h)	80	138	218	305
Rated flow rate G31 (g/h)	79	136	214	300
8 LPG G30/31 - 50 mbar	AUX	SR	R	UR2
Rated heating capacity (kW)	1.0	1.8	3.0	4.1
Nozzle diameter (1/100 mm)	43	58	74	80
Pre-chamber (printed on nozzle)	(H2)	(M)	(Z)	(F4)
Reduced flow rate (W)	400	500	1000	1500
Rated flow rate G30 (g/h)	73	131	218	298
Rated flow rate G31 (g/h)	71	129	214	293
9 Town gas G110 - 8 mbar	AUX	SR	R	UR2
Rated heating capacity (kW)	1.0	1.75	2.8	3.4
Nozzle diameter (1/100 mm)	145	185	260	340
Pre-chamber (printed on nozzle)	/8	/2	/3	0190
Reduced flow rate (W)	400	500	800	1200

The nozzles not provided are available at Authorised Service Centres.



# Installation

## 5.2 Positioning



**Heavy appliance**  
**Crushing hazard**

- Position the appliance into the cabinet cutout with the help of a second person.



**Pressure on the door**  
**Risk of damage to the appliance**

- Never use the oven door to lever the appliance into place when fitting.
- Avoid exerting too much pressure on the oven door when open.
- Do not use the handle to lift or move this appliance.



**Heat production during appliance operation**  
**Risk of fire**

- Veneers, adhesives or plastic coatings on adjacent furniture should be temperature-resistant (not less than 90 °C).

## Dimensions

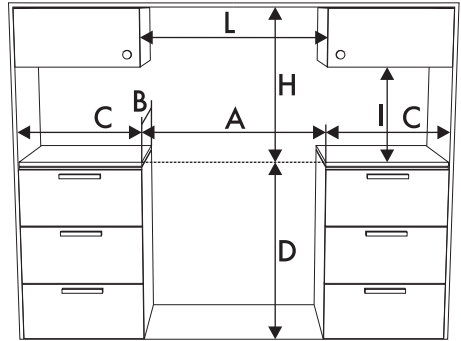

<b>A</b>	900 mm
<b>B</b>	600 mm
<b>C<sup>1</sup></b>	450 mm
<b>D</b>	900 mm
<b>H</b>	750 mm
<b>I</b>	450 mm
<b>L<sup>2</sup></b>	900 mm

<sup>1</sup> Minimum distance from side walls or other flammable material.

<sup>2</sup> Minimum cabinet width (=A).



## General information

This appliance may be installed next to walls, one of which must be higher than the worktop, at a minimum distance of 50 mm from the side of the appliance, as shown in figures **A** and **C** relative to the installation classes.

Any wall units positioned above the worktop of the appliance must be at a minimum distance of at least 750 mm.

If a hood is installed above the hob, refer to the hood instruction manual to ensure the correct clearance is left.

Depending on the type of installation, this appliance belongs to classes:

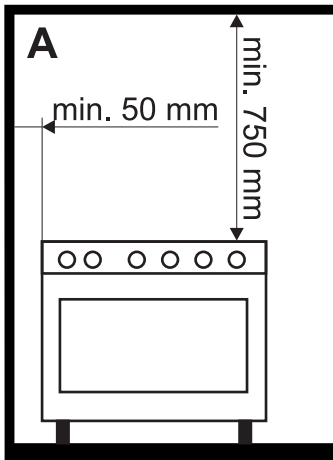

**A - Class 1**  
(Free-standing appliance)

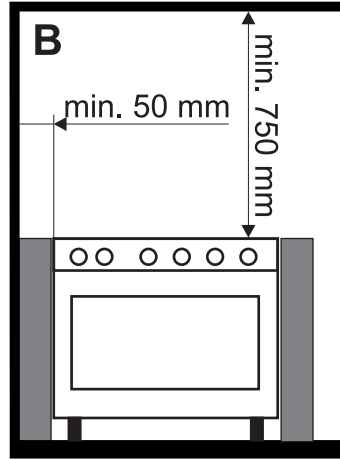

**B - Class 2 subclass 1**  
(Built-in appliance)

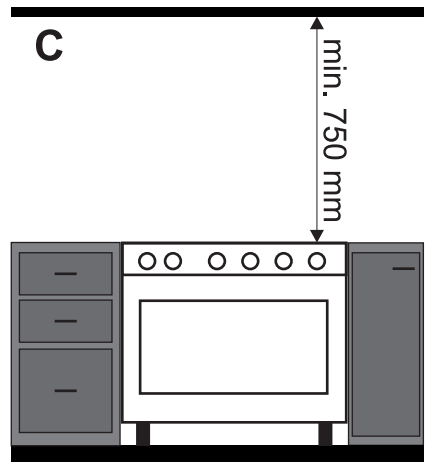

**C - Class 2 subclass 1**  
(Built-in appliance)



The appliance must be installed by a qualified technician and according to the regulations in force.



# Installation

## Positioning and levelling



**Heavy appliance**  
**Risk of damage to the appliance**

- Insert the front feet first and then the rear ones.

The appliance must sit level on the floor to ensure stability.

- After making the gas and electrical connections, level and stabilise the appliance on the floor by screwing the foot in or out.

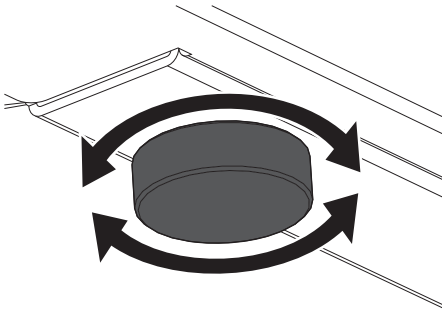

## Assembling the upstand



The supplied upstand is an integral part of the product and it is recommended to fasten it to the appliance prior to installation.

The upstand must always be positioned and secured correctly on the appliance.

1. Place the upstand on the worktop.
2. Line up the slots of the upstand (**A**) with the holes on the rear edge of the hob (**B**).

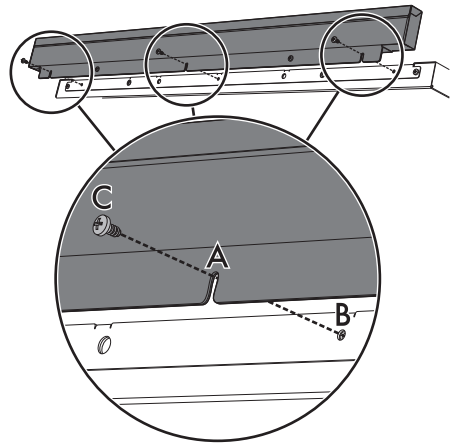

3. With the aid of a screwdriver, fasten the upstand to the hob using the supplied screws (**C**).



## Fastening to wall (where present)

1. Unscrew the screw behind the hob near the gas connection.

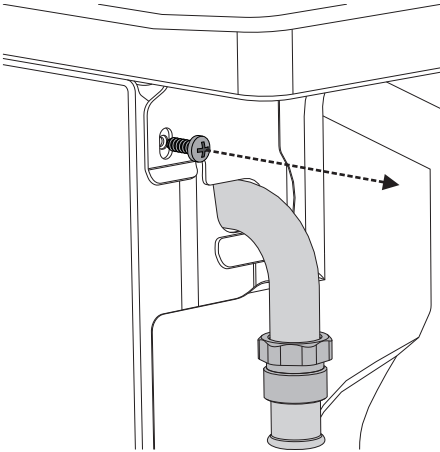

2. Attach the chain to the cooker using the screw removed in the previous step.

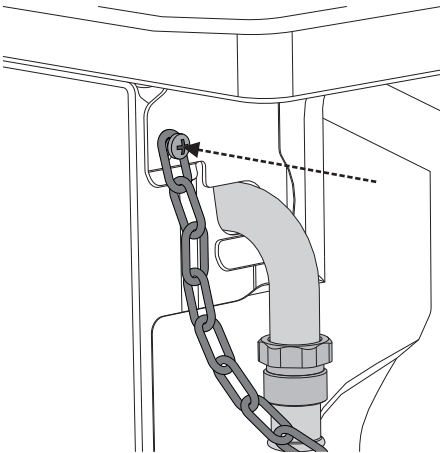

3. Stretch the chain out horizontally so that the other end touches the wall.

4. Mark the position for the hole on the wall.

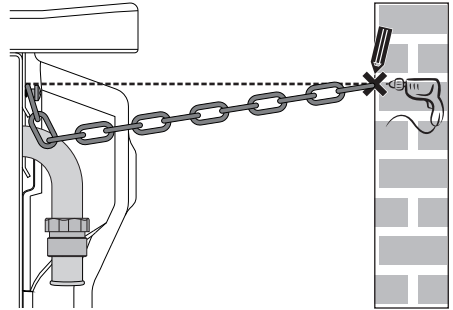

5. Drill a hole at the marked position and insert a wall plug.

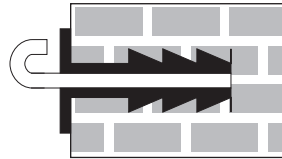

6. Attach the chain and push the appliance towards the wall.

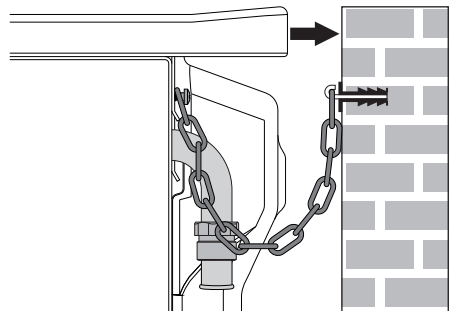

The length of the chain must be as short as possible to prevent the appliance from tipping forwards or diagonally or from moving sideways.



# Installation

## 5.3 Electrical connection



**Power voltage  
Danger of electrocution**

- Have the electrical connection performed by authorised persons.
- Use personal protective equipment.
- The appliance must be connected to ground in compliance with electrical system safety standards.
- Disconnect the mains power supply.
- Do not pull the cable to remove the plug.
- Use cables withstanding a temperature of at least 90 °C.
- The tightening torque of the screws of the terminal board leads must be 1.5 - 2 Nm.

### General information

Check the grid characteristics against the data indicated on the plate.

The identification plate bearing the technical data, serial number and brand name is visibly positioned on the appliance.

Do not remove this plate for any reason.

Perform the ground connection using a wire that is 20 mm longer than the other wires.

The appliance can work in the following modes:

### Pyrolytic models

- **220-240 V 2<sup>~</sup>**

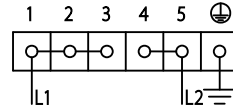

**3 x 2.5 mm<sup>2</sup> three-core** cable.

- **220-240 V 3<sup>~</sup>**

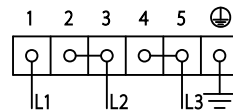

**4 x 1.5 mm<sup>2</sup> four-core** cable.

- **220-240 V 1N<sup>~</sup>**

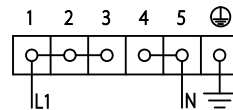

**3 x 2.5 mm<sup>2</sup> three-core** cable.

- **380-415 V 2N<sup>~</sup>**

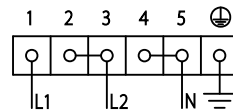

**4 x 1.5 mm<sup>2</sup> four-core** cable.

- **380-415 V 3N<sup>~</sup>**

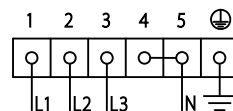

**5 x 1.5 mm<sup>2</sup> five-core** cable.



## Access to the terminal board (pyrolytic models only)

To connect the power supply cable, you must access the terminal board on the rear casing:

1. Remove the screws fastening the plate to the rear casing.

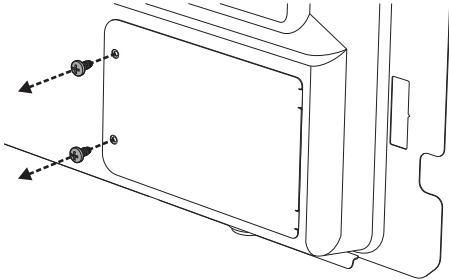

2. Gently rotate the plate and remove it from its seat.

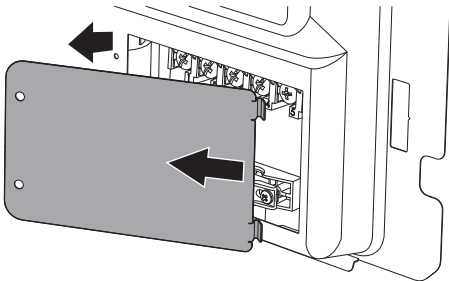

3. Proceed with installation of the power supply cable.

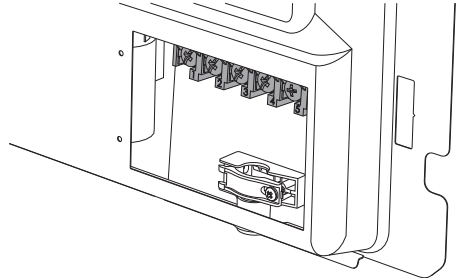

It is recommended to slacken off the cable clamp screw before installing the power supply cable.

4. When you have finished, reposition the plate on the rear casing and fasten it in place with the previously removed screws.

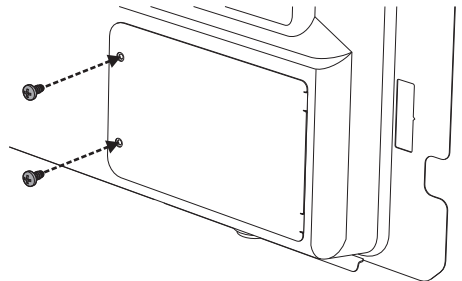



# Installation

## Multifunction models

- 220-240 V 1N~

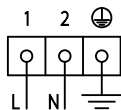

**3 x 1.5 mm<sup>2</sup> three-pole** cable.



The values indicated above refer to the cross-section of the internal conductor.



The aforementioned power cables are sized taking into account the coincidence factor (in compliance with standard EN 60335-2-6).

## Fixed connection

Fit the power line with an all-pole disconnection switch in compliance with installation regulations.

The circuit breaker should be located near the appliance and in an easily reachable position.

## Connection with plug and socket

Make sure that the plug and socket are of the same type.

Avoid using adapters, gang sockets or extensions as these could cause overheating and a risk of burns.

## 5.4 Instructions for the installer

- The plug must be accessible after installation. Do not bend or trap the power cable.
- The appliance must be installed according to the installation diagrams.
- Do not try to unscrew or force the threaded elbow of the fitting. You may damage this part of the appliance, which may void the manufacturer's warranty.
- Use soap and water to check for gas leaks on all connections. **DO NOT** use naked flames to find leaks.
- Turn on all the burners separately and at then all together to make sure that the gas valve, burner and ignition are working properly.
- Turn the burner knobs to the minimum position and check that the flame is stable for each individual burner and all the burners together.
- If the appliance does not work correctly after having carried out all the checks, contact your local Authorised Service Centre.
- Once the appliance has been installed, please explain to the user how to use it correctly.