



EQUIPMENT

COMMERCIAL MICROWAVE OVEN PRCS511TS-B



Powerline Medium Duty Microwave Ovens offer fast cooking in a space saving design. Durable and stackable, these ovens can help any foodservice operator serve consistently hot food.

VERSATILE AND EFFICIENT

These Medium Duty Microwave Ovens easily defrost and cook most frozen foods. It is an ideal unit for small restaurants, bars, cafes, or small convenience stores.

STANDARD FEATURES

- 1000 Watts of power for fast heating
- Ample 25 liter capacity
- Stainless steel interior, exterior, and handle
- No turntable, full sized (fixed) grease repellent ceramic plate
- 3 cooking stages with program cooking menu
- Up to 10 programmable menu items (100 item option)
- Durable construction insures longevity
- Easy to use touch controls with aluminum handle
- User friendly controls make for simple operation
- Very easy to clean
- Worldwide service network provides product support

COMMERCIAL MICROWAVE OVEN PRCS511TS-B

Technical Data

Configuration	Counter top
Control system	Touch
Number of programmable control pads	10
Number of programmable stages	3
Exterior construction	Stainless steel
Interior construction	Stainless steel
Removable ceiling cover	Yes
Air filter	No
Gastronorm compatible	No
Internal light	Yes
Display	LED
Stackable	Yes
Power levels	5
Multiple quantity setting X2 PAD	Yes
Time entry options	Yes
Safety interlock system	Yes
Exterior dimensions (L x W x H)	431 x 511 x 311mm
Interior dimensions (L x W x H)	346 x 327 x 200mm
Defrost indicator	Yes
Defrost selector pad	Yes
Program pad	Yes
Usable cavity space	25L
Microwave sound/noise (dBA)	63
Power consumption	1500W(120V) 1550W(220-240V)
Power output	1000W
Number of magnetrons	1 (Bottom)
Cooling system	Axel flow fan
Power source	120/60/1, 230/50/1, 240/50/1
Container quantity (40ft ³)	623
Product weight	14.6 Kg
Shipping weight	16.2 Kg
Shipping carton dimensions (LxWxH)	581 x 460 x 385mm

Detail & Dimensions

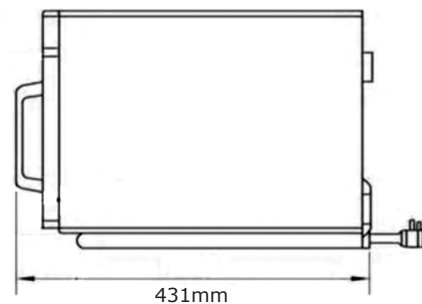
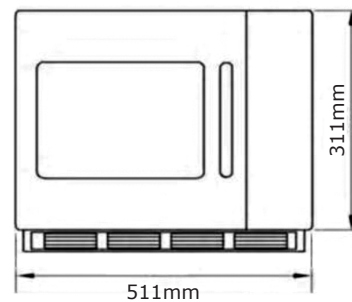

As continued product improvement is a policy of Powerline, specifications are subject to change without notice.



POWERLINE EQUIPMENT COMPANY

Pulaski Street, Norwalk, CT 06851 USA. Tel: 203-847 2357 Fax: 203-847 6480

www.powerlineequip.com