

Combi steamer

Project _____
 Item _____
 Quantity _____
 FCSI section _____
 Approval _____
 Date _____

Model

Convotherm 4 easyTouch

- easyTouch
- 6+1 Shelves GN 1/1
- Electric
- Boiler
- Disappearing door



Key features

- ACS+ operating modes: Steam, Combi-steam, Convection
- ACS+ Extra Functions:
 - Crisp&Tasty – 5 moisture-removal settings
 - BakePro – 5 levels of traditional baking
 - HumidityPro – 5 humidity settings
 - Controllable fan – 5 speed settings
- easyTouch 9" full-touch screen
- ConvoClean+ fully automatic cleaning system with eco, regular and express modes, including optional single-measure dispensing
- Ethernet interface (LAN)
- HygienicCare
- USB port integrated in the control panel
- TriColor indicator ring – indicates the current operating status
- Steam generated by high-performance boiler outside the cooking chamber
- Disappearing door: more space and greater safety at work (optionally available for an extra charge)

Standard features

- ACS+ (Advanced Closed System +) operating modes:
 - Steam (30-130°C) with guaranteed steam saturation
 - Combi-steam (30-250°C) with automatic humidity adjustment
 - Convection (30-250°C) with optimized heat transfer
- HygienicCare – food safety thanks to antibacterial surfaces:
 - easyTouch control panel
 - Door handle and recoil hand shower
- easyTouch user interface:
 - 9" full-touch screen
 - Press&Go – automatic cooking using quick-select buttons
 - TrayTimer – load management for different products at the same time
 - Regenerate+ – flexible multi-mode regenerating function
 - ecoCooking – energy-save function
 - Low-temperature cooking / Delta-T cooking
 - Cook&Hold – cooks and holds in one process
 - 399 cooking profiles each containing up to 20 steps
 - On-screen help with topic-based video function
 - Start-time preset
- Multi-point core temperature probe
- Door handle with safety latch and sure-shut function
- Data storage for HACCP and pasteurization figures
- Preheat and cool down function

Options

- Steam and vapour removal – built-in condensation module (on request)
- ConvoGrill with grease management function (on request)
- ConvoSmoke – built-in food-smoking function
- Marine version (see separate datasheet)
- Prison version
- Available in various voltages
- Sous-vide probe, external connection
- Core temperature probe, external connection

Accessories

- ConvoLink – HACCP and cooking profile management PC software
- ConvoVent 4 condensation hood with grease filter
- ConvoVent 4+ condensation hood with grease and odour filter
- Signal tower – external operating-state indicator
- Banquet system (optionally as a package or individually): Plate rack, mobile shelf rack, transport trolley, thermal cover
- Stands in various sizes and designs
- Racks, choice of GN or BM versions (BM = standard baking sheet size)
- Stacking kits
- Care products for the ConvoClean+ fully automatic cleaning system (multiple and single-measure dispensing)



Front view

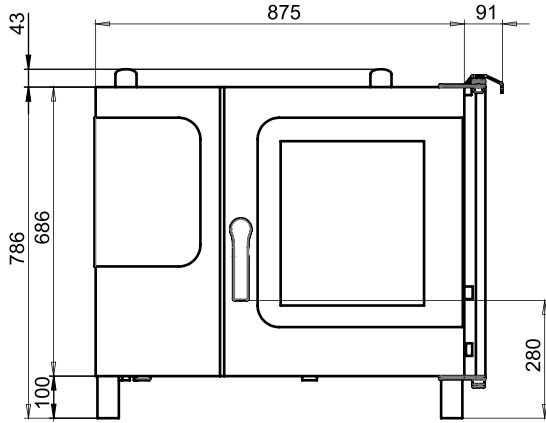

Connection positions

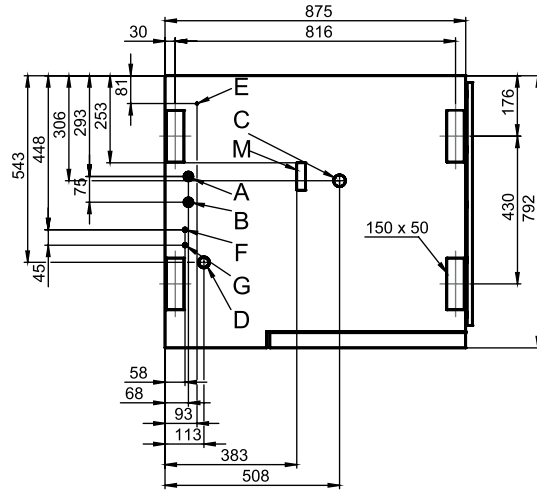

View from above with wall clearances

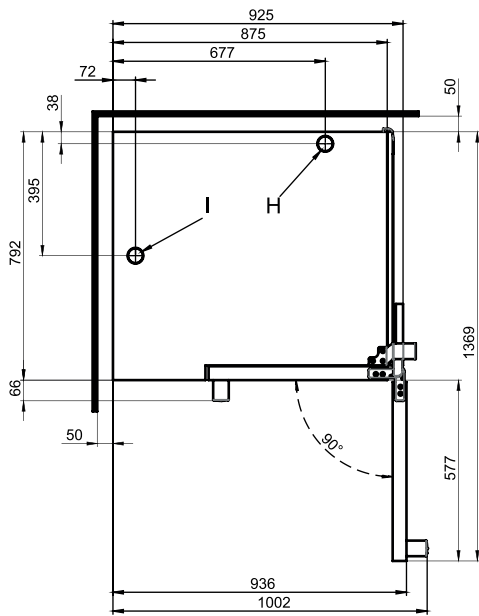

- A** Water connection (for boiler)
- B** Water connection (for cleaning, recoil hand shower)
- C** Drain connection DN 50
- D** Electrical connection
- E** Equipotential bonding
- F** Rinse-aid connection
- G** Cleaning-agent connection
- H** Air vent Ø 50 mm
- I** Ventilation port Ø 50 mm
- M** Safety overflow 80 mm x 25 mm

Dimensions and weights

Dimensions including packaging

Width x Height x Depth 1110 x 1010 x 940 mm

Weight

Empty weight without options* / accessories 129 kg

Weight of packaging 25 kg

Safety clearances**

Rear 50 mm

Right-hand side (disappearing door pushed back) 130 mm

Left (larger gap recommended for servicing) 50 mm

Top*** 500 mm

* Weight of options 15 kg max.

** Minimum distance from heat sources: 500 mm.

*** Depends on type of air ventilation system and nature of ceiling.

Installation instructions

Absolute tilt of unit in operation* max. 2° (3.5%)

* Adjustable feet included as standard.

Loading capacity

Max. number of food containers

GN 1/1*	6+1
600 x 400** baking tray	5
Plates max. Ø 32 cm, Ring spacing 66 mm**	20
Plates max. Ø 32 cm, Ring spacing 79 mm**	15

Maximum loading weight

GN 1/1 / 600 x 400	
Per combi steamer	30 kg
Per shelf level	15 kg

* Matching rack included as standard.

** Matching rack available as an accessory.

Electrical supply

3N~ 400V 50/60Hz*

Rated power consumption	11.0 kW
Rated current	15.9 A
Fuse rating	16 A
RCD (GFCI), frequency converter (single phase)	Type A (recommended), type B/F (optional)
Recommended conductor cross-section	5G4

3~ 230 V 50/60Hz*

Rated power consumption	10.9 kW
Rated current	27.4 A
Fuse rating	35 A
RCD (GFCI), frequency converter (single phase)	Type A (recommended), type B/F (optional)
Recommended conductor cross-section	4G6

3~ 200 V 50/60Hz*

Rated power consumption	10.9 kW
Rated current	31.5 A
Fuse rating	35 A
RCD (GFCI), frequency converter (single phase)	Type A (recommended), type B/F (optional)
Recommended conductor cross-section	4G6

3~ 400 V 50/60Hz*

Rated power consumption	11.0 kW
Rated current	15.9 A
Fuse rating	16 A
RCD (GFCI), three-phase frequency converter	Type B/F (recommended)
Recommended conductor cross-section	5G4

* Connection to energy optimization system included as standard.

PLEASE NOTE: If the ConvoSmoke option is chosen, the only voltages available are 3~ 230V 50/60Hz and 3N~ 400V 50/60Hz.

Water connection

Water supply

Water supply	2 x G 3/4" permanent connection, optionally including connecting pipe (min. DN13 / 1/2")
Flow pressure	150 - 600 kPa (1.5 - 6 bar)

Appliance drain

Drain version	Permanent connection (recommended) or funnel waste trap
Type	DN50 (min. internal Ø: 46 mm)
Slope for waste-water pipe	min. 3.5% (2°)

Water quality

Water-supply connection A* for boiler, Water-supply connection B* for cleaning, recoil hand shower

General requirements	Drinking water, typically hard water
Total hardness	4 - 20 °dh / 70 - 360 ppm / 7 - 35 °TH / 5 - 25 °e
pH value	6.5 - 8.5
Cl ⁻ (chloride)	max. 60 mg/l
Cl ₂ (free chlorine)	max. 0.2 mg/l
SO ₄ ²⁻ (sulphate)	max. 150 mg/l
Fe (iron)	max. 0.1 mg/l
Temperature	max. 40 °C
Electrical conductivity	min. 20 µS/cm

* See diagram of connection positions, page 2.

Water consumption

Water-supply connections A, B

Ø Consumption for cooking**	3.0 l/h
Max. water flow rate	15 l/min

** Including water used for cooling the wastewater.

PLEASE NOTE: See diagram of connection positions, page 2.

Emissions

Heat output	
Latent heat	2100 kJ/h / 0.58 kW
Sensible heat	2500 kJ/h / 0.69 kW
Waste water temperature	
	max. 80 °C
Noise during operation	
	max. 70 dBA

ACCESSORIES

(Please refer to the Accessories brochure for detailed information)

Stacking kit

Permitted combinations	6.10 on 6.10 6.10 on 10.10
------------------------	-------------------------------

For a combination of two electric appliances

Select "Stacking kit for Convotherm 4 electric appliances"

For a combination of one electric appliance and one gas appliance in the stacking kit

Select "Stacking kit for Convotherm 4 electric appliances" if:

Bottom combi steamer	EB/ES
Top combi steamer	GB/GS

Select "Stacking kit for Convotherm 4 gas appliances" if:

Bottom combi steamer	GB/GS
Top combi steamer	EB/ES

Condensation hood ConvoVent 4*

Electrical supply

Rated voltage	1N~ 200-240V 50/60Hz
Rated power consumption	260 W
Rated current	1.9 A
Fuse rating	2.5 A

Dimensions excluding packaging

Width x Height x Depth	877 x 240 x 1085 mm
Weight excluding packaging	66 kg

Safety clearance above**	500 mm
---------------------------------	--------

* Condensation hoods specially designed for stacking kits are available.

** Depends on type of air ventilation system and nature of ceiling.

Condensation hood ConvoVent 4+*

Electrical supply

Rated voltage	1N~ 200-240V 50/60Hz
Rated power consumption	260 W
Rated current	1.9 A
Fuse rating	2.5 A

Dimensions excluding packaging

Width x Height x Depth	877 x 373 x 1085 mm
Weight excluding packaging	85 kg

Safety clearance above**	500 mm
---------------------------------	--------

* Condensation hoods specially designed for stacking kits are available.

** Depends on type of air ventilation system and nature of ceiling.

Please observe the following points:

- This document is to be used solely for planning purposes.
- Please refer to the Installation Manual for further technical data and guidance on installation and positioning.